

Santo Domingo, D.N.

20 de febrero del 2026

Sres.

Junta Central Electoral de la República Dominicana

Atc. Departamento de Compras y Contrataciones

Referencia JCE-CCC-CP-2025-0033: "Suministro e instalación de un (1) sistema de detección y supresión de incendio".

Es un placer presentar nuestra propuesta técnica para el suministro de una solución llave en mano de un sistema de aviso de incendio acompañado con supresión en la bóveda y lamparas de emergencias distribuida en el Centro de Documentacion ubicado en la Avenida John F. Kennedy,

Proponemos una solución robusta con el suministro de un Panel de Incendio Kidde modelo VS4 by Edwards, un producto americano perteneciente al grupo CARRIER. Aprobado NFPA, UL y otras certificaciones.

OFERTA TECNICA Y LOGISTA DE TRABAJO ALCANCE

Nuestra propuesta se centra en la instalación de un sistema de alarma contra incendios de vanguardia, que cumple con los más altos estándares de seguridad y tecnología. Utilizando el panel KIDDE VS4, un equipo reconocido por su fiabilidad y capacidad de expansión, garantizamos un sistema completamente direccionable, capaz de identificar con precisión la ubicación exacta de cualquier evento de alarma.

Este enfoque no solo acelera la respuesta ante una emergencia, sino que también minimiza las falsas alarmas, optimizando la seguridad y la continuidad de las operaciones en su edificio. Todos los trabajos se realizarán conforme a las normas NFPA-72, y se incluirá la certificación correspondiente para asegurar el cumplimiento legal y la calidad de la instalación.

Alcance del Proyecto

El alcance de este proyecto está claramente definido para garantizar la entrega de un sistema de alarma contra incendios completo y funcional, desde el suministro de equipos hasta la puesta en marcha y la capacitación.

- **Suministro de Equipos y Materiales:** Provisión de todos los equipos y materiales especificados en la propuesta: panel KIDDE by Edwards, detectores, pulsadores, luces estrobo, anunciador remoto, módulos, baterías y todo el cableado, y accesorios necesarios), en tubería MT y tuberías BX, conectores y cajas octogonales para cada detector y lámpara de emergencia.
- **Instalación Física:** Montaje del panel de control, dispositivos de detección y notificación, y el tendido de todo el cableado y tuberías requeridos para el sistema, siguiendo las mejores prácticas y estándares de la NFPA-72.
- **Configuración y Programación:** Programación completa del panel Edwards i064 para direccionar cada dispositivo, configurar zonas de alarma, secuencias de notificación y la comunicación por correo electrónico.
- **Implementación de agente limpio NOVEC 1230** en la bóveda,
- **Pruebas y Puesta en Marcha:** Realización de pruebas exhaustivas de todos los componentes y del sistema completo para verificar su correcto funcionamiento antes de la entrega final.
- **Certificación y Documentación:** Emisión de una certificación NFPA-72, que valida el cumplimiento de la instalación, junto con la entrega de manuales y diagramas del sistema.
- **Capacitación del Personal:** Proporcionar una sesión de entrenamiento al personal designado para el uso diario del sistema, incluyendo la interpretación de alertas y procedimientos básicos.
- **Garantía:** Un (1) año de garantía en piezas y servicios a partir de la fecha de entrega del proyecto.

Con el objetivo de poder cumplir con la entrega en un máximo de 4 semanas, hemos contemplado usar tres grupos de trabajo. Un primer grupo encargado de instalar el sistema de detección compuesto por:

PANEL KIDDE VS4



Estamos proponiendo el modelo VS4 que admite 4 lazos de hasta 250 direcciones de dispositivos. Entre sus características se destaca:

- Autoprogramable, lo que facilita la instalación y manejo
- Compatible con BACNET lo que facilita la integración con HIKCENTRAL
- Cumple norma NFPA y UL
- Acepta hasta siete (7) Anunciadores. Mas detalles en ficha técnica anexo.

Licencia BACNET

401000558 HikCentral-P-BACNet-Module

D36 ADL 401000558

Es un modulo que va a permitir la gestión de integrar los mensajes y estatus del panel con el HIKCENTRAL. Licencia incluida en el precio.

El Equipo 1 serán encargado de instalar:

Panel VS4

2 Anunciadores (según el levantamiento)

77 Detectores de Humo direccionable

13 Detectores de calor direccionable

18 Estaciones Manuales

Calle José López No, 1 Esq. John F. Kennedy T. 809-227-6060

30 Sirena
1 Tarjeta de Comunicación BACNET
Materiales Varios (Cables, Tuberias)

Sistema de Alarmas de incendios Suc. Junta Central Electoral		
Código	Descripción	Cantidad
A21826	REPLACEMENT ELECTRONICS ASSEMBLY, FOUR LOOP, VS SERIES, SPANISH	1.00
A16755	LCD TEXT ANNUNCIATOR WITH COMMON CONTROLS. ENGLISH. RED	2.00
A12056	KEY LOOKED ANNUNCIATOR COVER, 1 UNIT	2.00
A13246	ETHERNET PROGRAMMING/DIAGNOSTICS INTERFACE, RJ45, MOUNTS TO BASE PLATE	1.00
A20511	KIDDE INTELLIGENT MULTI-CRITERIA OPTICAL SMOKE DETECTOR UL/ULC.	77.00
A16758	INTELLIGENT FIXED TEMPERATURE/RATE-OF-RISE HEAT DETECTOR	13.00
A21119	4-inch Detector Mounting Base c/w Trim Skirt	90.00
A17428	COMPACT WALL HORN/STROBE, 15-75CD, RED, FUEGO MARKING	30.00
A11573	ESTACION MANUAL DE INCENDIO DE DOBLE ACCION VS	18.00
A14006	FIRE ALARM CABLE, RISER-FPLR, 2-18 AWG SOLID BARE COPPER CONDUCTORS	1.00
A18716	Synchronization Output Module (One-gang standard mount)	7.00
A20829	MULTI-PROTOCOL BRIDGE MODBUS RTU, MODBUS TCP, BACNET MSTP, BACNET IP/ETH, AND DN	1.00
A10670	BATERIA 12VDC-12AH	2.00
A21115	FIELD SERVER BRIDGE BRACKET FOR FSB-PC2 OR FSB -PCLW	1.00
A14006	FIRE ALARM CABLE, RISER-FPLR, 2-18 AWG SOLID BARE COPPER CONDUCTORS	1.00
A23106	HikCentral-P-Integration-BACnet/Module	1.00
A23107	Remote Installation Service	4.00
S00164	MATERIALES MISCELANEOS DE INSTALACION	1.00
S00025	ALQUILER EQUIPOS ESPECIALES	1.00
S00434	MANO DE OBRA REPARACION Y SUBSANACION SHEETROCK	1.00
S00216	PROGRAMACION Y CONFIGURACION	1.00
S00366	DIRECCION Y SUPERVISION TECNICA	1.00
S00148	MANO DE OBRA INSTALACION	1.00

El Segundo Grupo de Trabajo será el responsable de implementar todos los materiales necesarios para el suministro del Agente limpio. Los equipos y materiales a utilizar son los siguientes:

- 1 Módulo de supresión de incendio
- 135 Libras de Agente Limpio instalado en un cilindro especial
- 2 Detectores de Humo Edwards en zona cruzada para evitar falsa alarma
- Cables, Tuberias y demás componentes necesarios.
- (Ver ficha técnica adjunto)

Sistema de Agente Limpio Boveda de Documentos JCE

Código	Descripción	Cantidad	p
A15045	FACP, 1 LOOP, 64 INTELLIGENT DEVICES MAX, 2 CLASS B NAC'S, 4.25A POWER SUPPLY.	1.00	
A12434	MODULO PARA EXTINCION AUTOMATICA DE INCENDIO	1.00	
A18395	EDWARDS INTELLIGENT MULTI-CRITERIA OPTICAL SMOKE DETECTOR UL/ULC.	2.00	
A13166	STANDARD DETECTOR BASE	2.00	
A17428	COMPACT WALL HORN/STROBE, 15-75CD, RED, FUEGO MARKING	2.00	
A11572	ESTACION MANUAL DE DOBLE ACCION DE COLOR AMARILLO	1.00	
A12823	PULSADOR PARA ABORTAR DESCARGA DE EXTINTOR	1.00	
A21977	164 LB CYLINDER / 1.25" VALVE ASSEMBLY (500 PSI / 34.5	1.00	
A21976	Clean Agent FK-5-1-12 UL/FM FFT1230 (per pound Lb)	135.00	
A13175	STRAP, 40 & 70 LB. CYLINDER MODELO	1.00	
A21979	ELECTRICAL ACTUATOR 24 VDC STACKABLE, SUPERVISORY	1.00	
A21980	MECHANICAL ACTUATOR	1.00	
A12503	NOZZLE 3/4" SS, 180 GRADOS	1.00	
A21982	FLEXIBLE HOSE 1.25" SINGLE BRAID; NPT -NPT (USE WITH 164 LB. CYLINDER)	1.00	
A21984	PRESSURE OPERATING SWITCH (NC/NO) SPDT - INCLUDES CONDUIT CONNECTOR (PS37CC)	1.00	
A21983	KEY MAINTENANCE SWITCH	1.00	
A21985	(INGLÉS/ESPAÑOL) - EVACUATION WARNING SIGN IF ALARM SOUNDS. 10"X14"(ENGLISH/SPANISH)	1.00	
A15924	LETREROS EN SINTRA AVISO DE EXTINCION DISPARADA 10" X 14"	1.00	
A13171	STI, COBERTOR "STOPPER I DE ESTACION MANUAL DE INC	1.00	
A11455	DUAL INPUT MODULE	1.00	
A10773	CABLE 18/2 SOLIDO DE COLOR ROJO	1.00	
A13779	BATERIA 12V/7AH.	2.00	
A13117	SOFT CALC	1.00	
S00104	FLETE	1.00	
S00164	MATERIALES MISCELANEOS DE INSTALACION	1.00	
S00366	DIRECCION Y SUPERVISION TECNICA	1.00	
S00148	MANO DE OBRA INSTALACION	1.00	



El tercer grupo será encargado de instalar las 35 lamparas de emergencia para funcionar en caso de corte de energía. Para esto, recomendamos la marca SUNLITE la cual ofrece:

- Bateria integrada con durabilidad de hasta 90 minutos de iluminación.
- Carcasa termoplástica de alta resistencia y retardante de llama color blanco
- Interruptor Incorporado.
- Certificada UL
- Instalacion bajo normas NFPA y Ministerio de Obras Puublicas (incluye registros octagonales, tubería eléctrica independiente y cable certificado UL 12 awg.

Referencia

Cot. Suministro y/o Instalacion Luces de emergencia Suc. Junta Central electoral Kennedy

Código	Descripción
A21714	LAMPARA DE EMERGENCIA LED 2W @200 LUMEN
S00164	MATERIALES MISCELANEOS DE INSTALACION
S00148	MANO DE OBRA INSTALACION

Ver Ficha Técnica Anexo

Debido a nuestra razón social y operaciones, tenemos un personal de servicio disponible todos los días del año para servicios de emergencia a clientes comerciales, corporativos, gubernamentales y residenciales. Por lo tanto, pueden contar con un apoyo técnico en caso de una urgencia 24/7.

Somos líder del mercado dominicano en tecnología para la seguridad y respuesta eficiente a las eventualidades, garantizando la seguridad de aquellos que nos confían la protección de lo que más valoran. Nuestra misión es construir un país más seguro a través de la tecnología y una respuesta eficiente a las eventualidades.

¿Que hace a A24 Alarma 24 la empresa líder en el sector de seguridad electrónica en República Dominicana? Nos preocupamos por brindar a nuestros clientes las soluciones tecnológicas más avanzadas e innovadoras del mercado, a precios competitivos y adaptadas a sus necesidades, asegurando garantía local con técnicos certificados por los fabricantes que representamos. Mas de 35 años de experiencia en el sector de la seguridad electrónica. • Respaldo de Dominican Watchman, empresa pionera en la seguridad, con más de 40 años, prestando servicio ininterrumpido.

- Ingenieros y técnicos certificados por la Asociación Latinoamericana de Seguridad (ALAS).
- Certificados por BASC en gestión de seguridad, organización internacional que certifica a empresas que desean optimizar la seguridad de su actividad.
- Central de monitoreo que labora bajo estándares internacionales. Nuestro Equipo: Nuestra Mayor Fortaleza Entre las fortalezas de la empresa, resaltamos la capacidad y experiencia de nuestro personal.

Seleccionamos empleados con altos valores morales que puedan cumplir con las demandas técnicas del trabajo. Son personas muy capacitadas y entre ellos encontrara Ingenieros Industriales, Electrónicos, eléctricos, informáticos y especialistas en diseño, los cuales se mantienen actualizados a través de nuestros programas de capacitación permanente.

¿Porqué elegirnos?

- **Nos comprometemos a entregar la documentación y plano eléctrico.**
- **Contamos con un personal altamente calificado y certificado en Incendio como en Hikvision**
- **Cumplimos Normas CPP, NFPA, ISO y BASC**

Debido a nuestra razón social y operaciones, tenemos un personal de servicio disponible todos los días del año para servicios de emergencia a clientes comerciales, corporativos, gubernamentales y residenciales.

Por lo tanto, pueden contar con un apoyo técnico en caso de una urgencia 24/7. Somos líder del mercado dominicano en tecnología para la seguridad y respuesta eficiente a las eventualidades, garantizando la seguridad de aquellos que nos confían la protección de lo que más valoran. Nuestra misión es construir un país más seguro a través de la tecnología y una respuesta eficiente a las eventualidades.

¿Que hace a A24 Alarma 24 la empresa líder en el sector de seguridad electrónica en República Dominicana? Nos preocupamos por brindar a nuestros clientes las soluciones tecnológicas más avanzadas e innovadoras del mercado, a precios competitivos y adaptadas a sus necesidades, asegurando garantía local con técnicos certificados por los fabricantes que representamos.

Mas de 35 años de experiencia en el sector de la seguridad electrónica. • Respaldo de Dominican Watchman, empresa pionera en la seguridad, con más de 50 años, prestando servicio ininterrumpido.

GARANTIA

12 Meses a partir de la entrega satisfactoria de los equipos.





20 de febrero del 2026
Santo Domingo

Señores:

Junta Central Electoral

Aten: Gerencia de compras

Asunto: **Carta de Certificación, crédito y Garantía**

Estimados Señores:

Por medio de la presente, ALARMA 24, S.R.L., con Registro Nacional de Contribuyentes (RNC) 101503114, declara en el proceso de compra JCE-CCC-CP-2025-0033:

1. Garantizamos que los equipos que estamos ofreciendo son nuevos, no reacondicionados ni remanufacturados.
2. Los equipos cuentan con una garantía por defectos de manufactura de 1 año a partir de la recepción satisfactoria de los equipos, no incluye daños causados por mal uso, efectos ocasionados por variables eléctricas o manipulación por un personal técnico No autorizado por Alarma 24.
3. Disponibilidad de entrega (3-4 semanas) a partir de la emisión de la orden de compras.
4. Otorgamos crédito a 30 días para el pago de los bienes adjudicados, plazo contado a partir del depósito de la factura correspondiente en la institución.

Agradecemos la oportunidad de participar en este proceso y reiteramos nuestro compromiso con la excelencia en la prestación de nuestros servicios.

Lucile Houellemont Jimenes
Presidente





Technology that saves lives

Intelligent Fire Alarm Systems

VS1, VS4



FDNY
COA 6229



7165-1657:
0244



Overview

Kidde brand intelligent life safety systems offer the power of high-end intelligent processing in configurations that deliver uncomplicated solutions for small to mid-sized applications. With intelligent detection, electronic addressing, automatic device mapping, optional Ethernet® connectivity, and a full line of easily-configured option cards and modules, these flexible systems offer versatility that benefits building owners and contractors alike.

The VS1 provides one Class A or Class B intelligent device loop that supports up to 64 device addresses, and two Class B Notification Appliance Circuits (NACs). Optional Class A device wiring is available with the use of a module.

The VS4 provides one Class A or Class B intelligent device loop that supports up to 250 device addresses. Loop controller modules may be added in combination to expand total system capacity in 250-point increments to up to 1,000 device addresses. VS4 panels include four NACs that may be wired for either Class A or Class B operation.

The RZ116-2 module adds even more capacity to VS installations by adding up to 16 conventional device circuits and two additional notification appliance circuits. This makes them ideal retrofit solutions that can accommodate new intelligent detectors, as well as existing conventional devices.

VS Series supports a wide range of high-end features, including:

- Intelligent modules, detectors, and bases
- GSA-REL Releasing Modules
- R-Series remote annunciators
- Integrated Carbon Monoxide gas sensing with KI-OSCD detectors including distinct audible signaling

Features

- Auto-programming speeds installation time
- Supports V-Series intelligent modules and detectors
- Form C contacts for alarm and trouble, Form A for supervisory
- Electronic addressing with automatic device mapping
- Optional Ethernet port (SA-ETH) for central station monitoring service, programming, diagnostics and a variety of system reports
- Two programmable switches with LEDs and custom labeling
- Supports Genesis horn silence over two wires, and UL 1971-compliant strobe synchronization
- Supports GSA-REL releasing module for fire suppression
- Class B or Class A wiring
- Ground fault detection by module
- Optional multi-protocol Field Server Bridge for interface to 3rd party Building Management Systems
- Supports up to eight serial annunciators, (LCD, LED-only, and graphic interface)
- Can use existing wiring for most retrofit applications
- Upload/download remotely or locally
- Optional USB module for local printing or programming using the configuration utility on a technician's laptop
- Two-level maintenance alert reporting
- Pre-alarm and alarm verification by point
- Adjustable detector sensitivity
- 4 x 20 character backlit LCD display
- Optional earthquake hardening: seismic Importance Factor 1.5
- Standalone operation
- Transmission test frequency by hour
- Alarm ON command manually activates alarm condition

Application

Kidde VS Series life safety systems are powerful intelligent solutions for small to mid-sized buildings. Advanced intelligent technology delivers the benefits of flexible system installation, while clean and easy-to-operate user interfaces make panel operation and system maintenance quick and intuitive.

The smart choice

Electronic addressing eliminates the tedium of setting dipswitches, and automatic device mapping ensures that each device resides on the system at its correct location. Meanwhile, innovative programming allows the designer to customize the system to precisely suit the needs of the building owner.

Reliability you can count on

The inherent fault-tolerant characteristics of Analog/Addressable Technology boosts the reliability of Kidde fire alarm systems. When combined with VS Series smoke and heat detectors, these systems deliver a level of dependability not previously available for small to mid-sized applications. All Kidde systems are built to exacting reliability benchmarks and meet international standards for quality, in addition to agency listings for dependability.

Clear-cut remote annunciation

Remote annunciation is a strong suit of the VS Series fire alarm systems. Up to eight annunciators can be installed on a single system. Compatible annunciators include a range of LED and LCD models that provide zone or point annunciation, as well as common control capabilities. VS control panels also supports graphic annunciation with optional graphic annunciator interface modules. Each interface provides common control and 32 LEDs.

Signals with a difference

VS Series NACs are configurable to fully support the advanced signaling technology of Kidde Genesis and Enhanced Integrity notification appliances. These devices offer precision synchronization of strobes to UL 1971 standards. For Genesis devices, enabling this feature allows horns to be silenced while strobes on the same two-wire circuit continue to flash until the panel is reset.

Programming and remote diagnostics

Kidde VS Series life safety systems are simple to set up, yet offer advanced programming features that put these small building panels into a class of their own. The auto programming feature quickly gets the panel operational using factory default settings. Basic zone and point settings can be programmed through the front panel interface, so the system is up and running in no time.

For more advanced system configuration and correlation groups programming, VS Series systems interface to a PC running compatible VS-CU software. This option offers full system configuration in the familiar Windows® operating environment. Connection is made to a laptop through the panel's optional RS-232 communications port, which can also be used to connect a system printer.

Among the many innovative features of VS Series control panels is the optional network card. This module provides a standard 10/100 Base T Ethernet® network connection that permits access to the control panel from any remote location with the correct communications protocols. The connection can be used to download to the panel from the VS-CU, or upload and view system reports using the VS-CU.

Available system reports include: Correlation groups, Device details, Device maintenance, History, Internal status, System configuration, System status, Walk test, Dialer, and CO runtime.

Flexibility built right in

Two fully-programmable front panel switch/LED combinations provide an added measure of flexibility. Their slide-in labels take the mystery out of custom applications, and present a clean finished appearance.

Perfect for retrofits

Kidde VS Series control panels are particularly well-suited to retrofit applications. All connections are made over standard wiring – no shielded cable required. This means that in most situations existing wiring can be used to upgrade a legacy control panel to VS technology without the expense or disruption of rewiring the entire building. VS control panels also support the ingenious RZ116-2 zone module, which adds up to 16 conventional circuits and two NACs. This combination easily accommodates new intelligent detection alongside existing conventional circuits, making it an superior solution in the retrofit market.

Scalable IP and Cellular Communications

The panel supports IP connectivity using the SA-ETH option card for monitoring services by a supervising station to meet NFPA 72 Chapter 26. The Ethernet card uses the FIBRO protocol to communicate with Sur-Gard System receivers (see page 5 for compatible receivers). Several popular third-party IP/Cellular communicators have been tested with the VS control panels and are compatibility listed to UL864. The IP/Cellular communicators meet NFPA72 2013 edition requirements for sole or secondary transmission paths. Using IP/Cellular communicators can reduce the cost of ownership by eliminating POTS lines. Please see the VS control panel compatibility documentation part number 3102354-EN for a full list of compatible communicators.

A complete line of accessories

VS Series life safety systems are supported by a complete line of analog/addressable detectors, modules and related equipment. Consult the Ordering Information section for details.

Dimensions

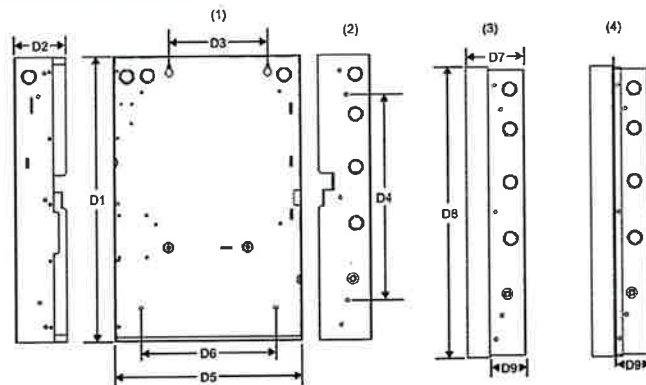

- (1) Surface Mounting Holes
 (2) Semi-flush mounting Holes
 (3) Backbox with Door Attached
 (4) Backbox with door and trim kit attached.

Panel dimensions, in (cm)

Model	D1*	D2	D3	D4	D5*	D6	D7	D8	D9
VS4	28.0 (71.1)	3.85 (9.8)	9.0 (22.8)	22.0 (55.8)	15.75 (40.0)	10.25 (26.0)	4.9 (12.4)	30.1 (76.4)	2.7 (6.8)
VS1	21.5 (54.6)	3.85 (9.8)	7.5 (19.0)	15.5 (39.4)	14.25 (36.2)	10.25 (26.0)	4.9 (12.4)	23.6 (59.9)	2.7 (6.8)

* Add 1-1/2 in. (3.81 cm) to D1 and D5 dimensions for trim kit. The trim kit provides 0.75 inches (1.9 cm) of trim to the top, bottom, and sides of the backbox.

System Layout

VS4

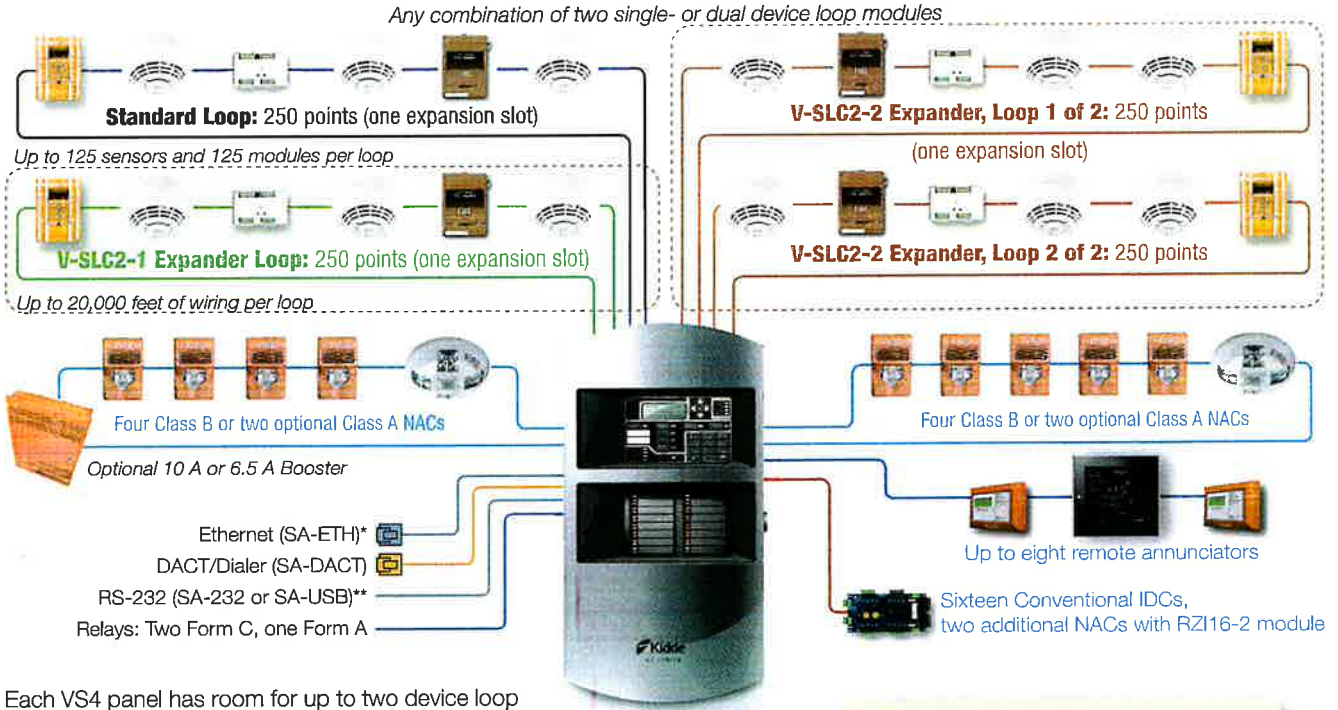

Each VS4 panel has room for up to two device loop controller modules in any combination of single or dual 250-device loops. VS4 comes with one loop that supports up to 125 detectors and 125 modules.

VS1

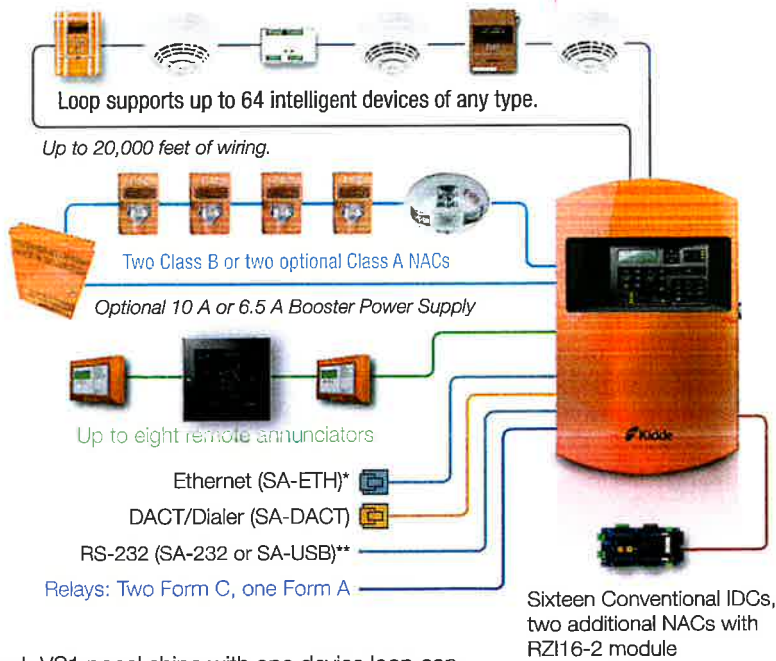

Each VS1 panel ships with one device loop controller that supports 64 devices of any type. This panel's device capacity cannot be expanded.

Panel Layout

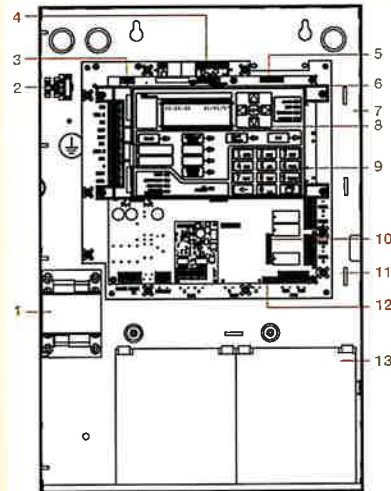

- 1 Transformer
- 2 Main AC wiring block & fuse holder
- 3 RS-232 card connector (J3)
- 4 Dialer card connection (J8)
- 5 Ethernet card connector (J1)
- 6 Main circuit board
- 7 Panel backbox enclosure
- 8 Operator interface
- 9 SLC card connector (J7)
- 10 Class A card connector (J2)
- 11 Tie wrap mounts
- 12 LED expander connector (J6)
- 13 Standby batteries

*SA-ETH supports: (1) remote connectivity for diagnostics & programming, (2) Central station monitoring to Sur-Gard IP Receivers.

**RS-232 supports: (1) Printer, (2) Programming Interface, (3) Use of Field Server Bridge (SA-FSB) for 3rd party Building Management Systems interface.

Wiring & Configuration

Device loop

The system provides one device loop circuit with a total capacity of 125 detectors and 125 module addresses. The loop circuit is supervised for opens, shorts, and grounds.

Circuit specifications	VS4	VS1
Device loops	One Class B or A loop, supporting 125 detectors and 125 modules. Expandable to four loops.	One Class B or A loop, supporting 64 devices of any kind.
Communication line voltage	Maximum 20 V peak-to-peak	
Circuit current	0.5 A max	
Circuit impedance	66Ω total, 0.5 μF, max	
Isolators	64 maximum	
Signal Synchronization	Supported on a system-wide basis (all device loops) when using an addressable notification appliance circuit (NAC) module and Genesis or Enhanced Integrity notification appliances.	

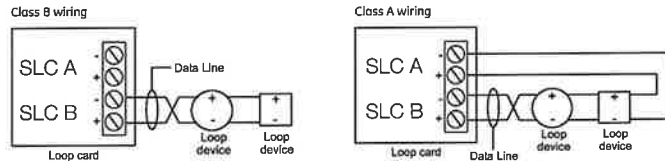

Notification appliance circuits (TB2)

VS4 control panels come equipped with four notification appliance circuits. VS1 control panels come with two NACs. Each circuit can be individually configured for continuous, temporal, synchronized, and coded output.

Specifications	VS4	VS1
Circuit Type	4 Class B or 2 Class A	2 Class B or 2 Class A with SA-CLA module
Voltage	24 VFWR	
Current	6.0 A total, 2.5 A max. per circuit at 120/230 VAC 60 Hz. 5.0 A total, 2.5 A max. per circuit at 230 VAC 50 Hz.	3.75 A total, 2.5 A max. per circuit at 120/230 VAC 60 Hz. 3.0 A total, 2.5 A max. per circuit at 230 VAC 50 Hz.
Impedance	26 Ω total, 0.35 μF max	
EOLR	15 K Ω, ½ W	
Synchronization	Supported system-wide	

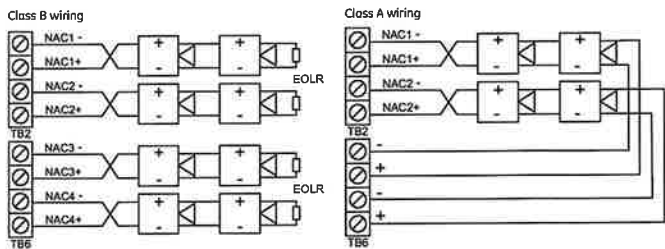

Marking indicates output signal polarity when the circuit is active. Polarity reverses when the circuit is not active. Wire notification appliances accordingly. Notification appliance polarity shown in active state.

Auxiliary & smoke power outputs (TB3)

The control panel provides two auxiliary power outputs that can be used for powering ancillary equipment such as remote annunciators and two wire smoke detectors. Aux 2 can be software selected to operate continuously. The circuit is supervised for shorts and grounds.

Circuit specifications

Circuit voltage range	21.9 to 28.3 V
Resettable circuit (Aux power 2)	24 VDC nominal at 500 mA
Continuous circuit (Aux power 1)	24 VDC nominal at 500 mA. Use this circuit for powering two-wire smoke detectors.

Note: Any current above 0.5 amp connected to both Aux 1 and 2 will reduce the total available NAC power by that amount.

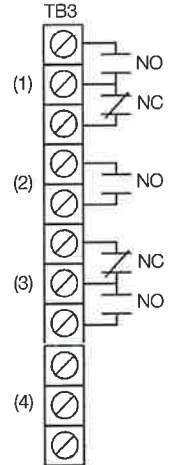

- (1) Trouble
- (2) Supervisory
- (3) Alarm
- (4) Smoke/Aux

Alarm, trouble, and supervisory relay (TB3)

The trouble relay is normally-open, held closed, and opens on any trouble event or when the panel is de-energized. The supervisory relay is normally-open, and closes on any supervisory event. The alarm relay changes over on any alarm event.

Relay specifications

	Alarm	Trouble	Supervisory
Type	Form C		Form A
Voltage	24 VDC at 1 A resistive		24 VDC at 1 A resistive

Relay circuits can only be connected to power-limited sources.

Annunciator loop (TB4)

The control panel provides a connection for up to eight serially driven and supervised remote annunciators.

Circuit specifications

Device loops	Class B (Style Y) or Class A (Style Z)
Circuit voltage	2.55 V
Circuit current	30 mA max
Circuit impedance	Up to 8 annunciators or 4000 feet

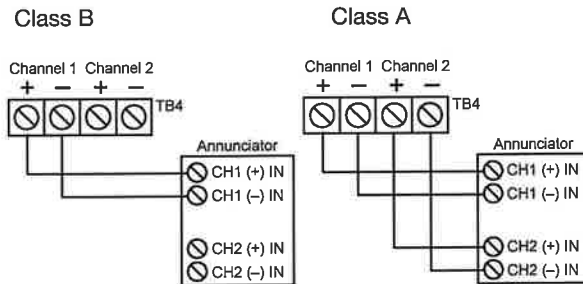

Option Cards

Kidde VS Series panels are supported by a complete line of modules and related equipment that enhance performance and extend system capabilities. Option cards plug directly into the control panel main circuit board or are connected to it with a ribbon cable. After installation, terminals remain accessible. The cabinet provides ample room for wire routing, keeping wiring neat at all times.

Single and Dual Loop Controller Cards

The V-SLC2-1 is a single loop controller card that can be used with the VS1 as a replacement for the standard 64-point loop, or with the VS4 as a 250-point expansion module.

The V-SLC2-2 is a 500-point dual loop controller card for the VS4 that provides two IDC circuits, each with 125 detector addresses and 125 module addresses.

Specifications	V-SLC2-1	V-SLC2-2
Device Addresses	VS4: one loop, 250 device addresses VS1: 64 addresses	VS4: two loops, 500 device addresses
Wiring	Class B or Class A	
Operating Voltage	24 VDC	
Operating Current (fully loaded loop)	Standby: 55 mA Alarm: 80 mA	Standby: 45 mA Alarm: 70 mA
<i>Note: These ratings do not include the use of two-wire smoke modules.</i>		
Communication Line Voltage	Max. 20.6 V peak-to-peak	
Terminal Rating	12 to 18 AWG (0.75 to 2.5 mm ²)	
Circuit Current	0.5 A max.	
Max total loop resistance	66 Ω	
Max total loop capacitance	0.5 μF	
Isolators	64 isolators maximum per loop (total both isolator bases and modules)	
Ground Fault Impedance	0 to 5 kΩ	
Operating Environment	32 to 120°F (0 to 49°C) 0 to 93% noncondensing at 90°F (32°C)	

SA-ETH Ethernet Interface Card/IP Communicator

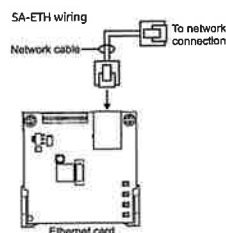

The SA-ETH card provides a standard 10/100 Base T Ethernet network connection for connecting to an intranet, a local network, or the Internet. The card supports IP connectivity for monitoring services by a supervising station to meet NFPA 72 Chapter 26. The Ethernet card uses the FIBRO protocol to communicate with Sur-Gard System receivers (see below). The card can be used to download configuration programming from the VS-CU to the panel.

The Ethernet card is installed on the plastic assembly and connects to the main circuit board via a ribbon cable.

SA-ETH specifications

Ethernet	10/100 Base-T
Operating environment	
Temperature	32 to 120°F (0 to 49°C)
Humidity	0 to 93% RH, noncondensing at 90°F (32°C)
Compatible Sur-Gard Receivers	SG-System I, II, III, IV and 5

RZI16-2 Remote Zone Interface Module

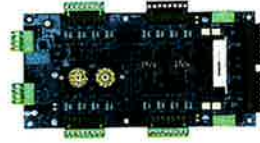

The RZI16-2 Addressable Remote Zone Interface Module is an addressable device that provides connections for sixteen Class B Initiating Device Circuits and two Class B Supervised Output Circuits. The inputs and outputs can be configured individually for several device types.

The RZI16-2 requires 18 consecutive addresses on the Signaling Line Circuit (SLC). Addresses are assigned electronically. There are no address switches to set.

The RZI16-2 incorporates two 8-segment DIP switches that are used to select the Alarm or Supervisory default device type for each of the 16 IDC circuits. The module also includes one 4-segment DIP switch used to select the default Relay or NAC output device type. Device types other than the default are accomplished through programming.

RZI16-2 Specifications

Voltage	
24V/Aux nominal:	24 VDC
Supervisory current:	250 mA at 24 VDC nominal
Alarm current:	1000 mA
24V/Aux minimum:	18.4 VDC
24V/Aux maximum:	26.4 VDC
NAC1, NAC2 nominal:	24 VDC
Current	
Standby current for 4.7 k EOL (U.S.)	4.8 mA/ circuit
Standby current for 3.9 k EOL (Canada)	5.7 mA/ circuit
Alarm current at nominal voltage	31.1 mA/ circuit
Relay outputs	
Quantity	2
Type Rating (pilot duty)	Programmable 24 VDC at 2.5 A
Input circuit wiring resistance	25 Ω per wire
Initiating device circuits	
Quantity	16
EOL resistor	4.7 kΩ (U.S.); 3.9 kΩ Canada
Zone voltage	22.78 V for 4.7 kΩ (U.S.) 22.08 V for 3.9 kΩ (Canada)
Alarm current	31.1 mA/ channel at nominal voltage
Alarm impedance range	< 680 Ω
Trouble impedance range	> 5.55 kΩ
Supervised output circuits	
EOL resistor	15 kΩ
Quantity	2
Short circuit detection	< 2.6 kΩ
Open circuit detection	> 61.9 kΩ
Contact ratings	24 VDC at 2.5 A (5 A for two NACs)
Compatible cabinets	MFC-A, VS4, APS

SA-DACT Dialer

The SA-DACT provides communications between the control panel and the central station over a telephone line system. It transmits system status changes (events) to a compatible digital alarm communicator receiver over the public switched telephone network. The dialer is capable of single, dual, or split reporting of events to two different account and telephone numbers. The modem feature of the SA-DACT can also be used for uploading and downloading panel configuration, history, and current status to a PC running the VS-CU.

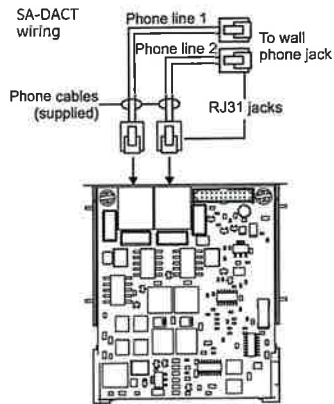

The dialer phone lines connect to connectors on the dialer's main circuit board. Phone line 1 connects to connector J4 and phone line 2 connects to connector J1.

The SA-DACT queues messages and transmits them based on priority (alarm, supervisory, trouble, and monitor). Activations are transmitted before restorations.

The SA-DACT is installed on the plastic assembly and connects to the main circuit board via a ribbon cable.

SA-DACT specifications

Phone line type	One or two loop-start lines on a public, switched network
Phone line connector	RJ-31/38X (C31/38X)
Communication formats	Contact ID (SIA DC-05)
Operating environment	
Temperature	32 to 120°F (0 to 49°C)
Humidity	0 to 93% RH, noncondensing at 90°F (32°C)

Compatible DACRs

Receiver	Models	Formats
Ademco	685	Contact ID
FBII	CP220	Contact ID
Osborne-Hoffman	OH 2000	Contact ID
Bosch	D6800	Contact ID
Silent Knight	9800	Contact ID
Sur-Gard	SG-MLR1, MLR2	Contact ID

The SA-USB Interface Card

The SA-USB Interface Card provides a USB connection to a supported printer or a connection to a PC. The card can be used for connecting a printer to the control panel to print system events. The card can also be used for uploading and downloading panel configuration, history, and current status to a PC running the configuration utility (CU).

SA-USB Specifications

Operating voltage	24VDC
Current Standby/Alarm	13 mA, max 20mA
Universal Serial Bus (USB) ports	1 USB Type A –host port J3 (printer connection) 1 USB Type B – device port J4 (CU connection)
Supported Printer	PT-1S
Printer communication speed	9600 baud
Operating environment	
Temperature	32 to 120°F (0 to 49°C)
Humidity	0 to 93% RH, noncondensing

SA-232 RS-232 interface

The SA-232 card provides an RS-232 interface with VS panels. It can be used for connecting a printer to the control panel to print system events. The card also can be used for connecting a computer to download a configuration program from the VS-CU to the control panel.

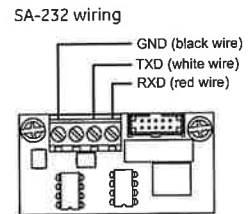

The RS-232 card is installed on the plastic assembly and connects to the main circuit board via a ribbon cable.

SA-232 specifications

Operating voltage	Standard EIA-232
Terminal rating	12 to 18 AWG (0.75 to 2.5 sq mm)
Operating environment	
Temperature	32 to 120°F (0 to 49°C)
Humidity	0 to 93% RH, noncondensing at 90°F (32°C)

SA-CLA Class A Module (VS1 only)

The SA-CLA card provides Class A capability for NAC wiring. Its terminal block provides the wiring connection for NAC return wiring. The card is required for annunciator Class A wiring even though this wiring does not return to the SA-CLA card. The SA-CLA is compatible with VS1 control panels only. VS4 panels are Class A Ready. The SA-CLA is installed directly to the control panel circuit board using its plastic standoffs and plug connection.

SA-CLA specifications

Operating voltage	24 VFWR
Operating current	3.75 A FWR total at 120/230 VAC 60 Hz 3.0 A FWR total at 230 VAC 50 Hz 2.5 A max per circuit
Circuit impedance	26 ohms, 0.35uF
Terminal rating	12 to 18 AWG (0.75 to 2.5 sq mm)
Operating environment	
Temperature	32 to 120°F (0 to 49°C)
Humidity	0 to 93% RH, noncondensing at 90°F (32°C)

D16L-VS LED Display Expander (VS4 only)

The D16L-VS LED Display Expanders provide LED annunciation for up to 16 zones. It provides two LEDs for each zone. Two D16L-VS LED display expanders can be installed in each VS4 panel.

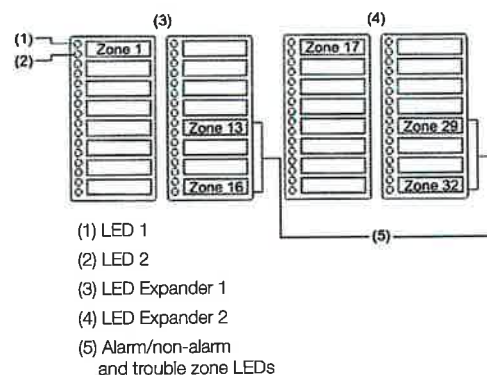

Specifications

	VS1	VS4
Device loops	1 loop Class B or Class A (Styles 4, 6, 7) supporting up to 64 device addresses (any combination of detectors and modules) Maximum T-taps: 63 (each device can be on its own branch)	1 loop, expandable to 4, Class A or B (Styles 4, 6, 7), each loop supporting up to 250 device addresses (125 detectors and 125 modules max.). Addresses 1 to 125 are for detectors and addresses 126 to 250 are for modules Maximum T-taps/loop: 124
Notification appliance circuits	2 Class B (Style Y), Class A (Style Z) optional 3.75 A FWR total at 120/230 VAC 60 Hz 3.0 A FWR total at 230 VAC 50 Hz 2.5 A FWR each max. per circuit	4 Class B (Style Y) or 2 Class A (Style Z) 6.0 A FWR total at 120/230 VAC 60 Hz 5.0 A FWR total at 230 VAC 50 Hz 2.5 A FWR each max. per circuit
Primary power	120 VAC, 60 Hz, 1.3 A max. 230 VAC, 50-60 Hz, 0.62 A max.	120 VAC, 60 Hz, 2.0 A max. 230 VAC, 50-60 Hz, 0.97 A max.
Base panel current standby	155 mA	172 mA
Base panel current alarm	204 mA	267 mA
Input zones	16 max.	32 max.
Remote annunciator	8 drops max., RS-485 Class B, Class A is optional Data line length: 4,000 ft. (1,219 m)	8 drops max., RS-485 Class A or B Data line length: 4,000 ft. (1,219 m)
Operating voltage	24 VDC panel	
Auxiliary power output circuit	Aux power 1: 500 mA, 24 VDC Aux power 2: 500 mA, 24 VDC (1 A possible if you reduce total available NAC power by 500 mA) Output: 28.3 to 21.9 VDC, special application Note: For a list of compatible devices, see the VS1 and VS4 Series Compatibility List (P/N 3102354-EN)	
Loop circuit	Maximum loop resistance: 66 Ω Maximum loop capacitance: 0.5 μ F Communication line voltage: Maximum 20.6 V peak-to-peak Operating current (fully loaded loop) Stand by: 55 mA/45 mA Alarm: 125 mA/115 mA (not including two-wire smoke modules) Circuit current: 0.5 A max. Style 4, 6, and 7 wiring Max. resistance between isolators: Limited only by overall wire run lengths 64 isolators maximum per loop (total both isolator bases and modules)	
Batteries	Type: Sealed lead acid Voltage: 24 VDC Charging current: 2.47 A max. Amp hour capacity: 26 Ah Standby operation: 24 hour or 60 hour Placement: Up to two 10 Ah batteries will fit in the VS1 control panel cabinet and two 18 Ah batteries will fit in the VS4 control panel cabinet. If larger batteries are required, use a battery cabinet.	
SA-DACT dialer	Phone line type: One or two loop-start lines on a public, switched network Phone line connector: RJ-31/38X (C31/38X) Communication formats: Contact ID (SIA DC-05) Operating current Standby/Alarm: 41 mA Max.: 100 mA FCC registration number: GESAL01BSADACT Industry Canada Registration number: 3944A-SADACT Ringer equivalence number: 0.1B	
Ground fault impedance	0 to 5 k Ω	
Alarm contact	Form C N.O. 24 VDC at 1 A (resistive load)	
Trouble contact	Form C 24 VDC at 1 A (resistive load)	
Supervisory contact	Form A N.O. 24 VDC at 1 A (resistive load)	
Environmental	Temperature: 0 to 49°C (32 to 120°F) Relative humidity: 0 to 93% noncondensing	
Terminal rating	All terminals rated for 12 to 18 AWG (0.75 to 2.5 mm ²)	



Technology that saves lives

Contact us

Phone: 888.244.9979 (Option 4)
 Email: kidde.fire@carrier.com
 Website: kidde-esfire.com

Kidde is a Carrier brand.
 8985 Town Center Pkwy,
 Bradenton, FL 34202

©2021 Carrier
 All Rights Reserved.

Ordering Information

Part	Description
VS4 Fire Alarm Systems	
VS4-G	Four loop system with one 250-point loop installed. 110v, gray door.
VS4-G-2	Four loop system with one 250-point loop installed. 230v, gray door.
VS4-G-2-PG	Four loop system with one 250-point loop installed. 230v, gray door, Portuguese.
VS4-G-2-SP	Four loop system with one 250-point loop installed. 230v, gray door, Spanish.
VS4-GC	Four loop system, one 250-point loop installed. 110v, gray door, LED strips, Canada.
VS4-GD	Four loop system, one 250-point loop installed. 110v, gray door, with dialer.
VS4-GF	Four loop system, one 250-point loop. 110v, gray door, LED strips, French Canada.
VS4-G-PG	Four loop system with one 250-point loop installed. 110v, gray door, Portuguese.
VS4-G-SP	Four loop system with one 250-point loop installed. 110v, gray door, Spanish.
VS4-R	Four loop system with one 250-point loop installed. 110v, red door.
VS4-R-2	Four loop system with one 250-point loop installed. 230v, red door.
VS4-RD	Four loop system, one 250-point loop installed. 110v, red door, with dialer.
SA-TRIM2	VS4 Flush mount trim, black.

VS1 Fire Alarm Systems	
VS1-G	One loop system with one 64-point loop installed. 110v, gray door.
VS1-G-2	One loop system with one 64-point loop installed. 230v, gray door.
VS1-G-2-PG	One loop system with one 64-point loop installed. 230v, gray door, Portuguese.
VS1-G-2-SP	One loop system with one 64-point loop installed. 230v, gray door, Spanish.
VS1-GD	One loop system, one 64-point loop installed. 110v, gray door, with dialer.
VS1-GL	One loop system, one 64-point loop installed. 110v, gray door, English Canada.
VS1-GL-F	One loop system, one 64-point loop installed. 110v, gray door, French Canada.
VS1-G-PG	One loop system with one 64-point loop installed. 110v, gray door, Portuguese.
VS1-G-SP	One loop system with one 64-point loop installed. 110v, gray door, Spanish.
VS1-R	One loop system with one 64-point loop installed. 110v, red door.
VS1-R-2	One loop system with one 64-point loop installed. 230v, red door.
VS1-RD	One loop system, one 64-point loop installed. 110v, red door, with dialer.
SA-TRIM1	VS1 Flush mount trim, black

Option Cards	
V-SLC2-1	Expansion module, one 250-device loop. For VS4 only.
V-SLC2-2	Expansion module, two 250-device loops, 500 devices total. For VS4 only.
RZI16-2	Remote Zone Interface Module. 16 Class B IDCs, 2 Class B Output. Bracket included.
SA-DACT	Dual Line Dialer/Modem, supports Contact ID, mounts in cabinet on base plate.
SA-232	RS-232 Serial Port for connection to printers & computers, mounts in cabinet.
SA-ETH	Ethernet Port, IP Communicator, mounts in cabinet on base plate.
SA-FSB	Field Server Bridge for connection to 3rd Party Building Management Systems. Supports BACnet and Modbus protocols. Mounts in the MFCA cabinet using the FSB-BRKT2 mounting plate. See separate SA-FSB datasheet K85010-0157 for additional information
SA-CLA	Class A adapter module. Provides Class A capacity on NACs. Mounts in cabinet on main board. VS1 systems only.
SA-USB	RS-232 Serial port for connection to printers & computers, mounts in cabinet
D16L-VS	LED Annunciator module, 16 X 2-LED zones (4 programmable for sup). Mounts in cabinet to right of LCD display. For VS4 only.
D8RY-VS	Canada only: LED Annunciator module, two LEDs per zone, 16 zones (4 alarm only, 8 supervisory only, 4 alarm or supervisory). Mounts in cabinet. For VS4 only.

Accessories	
CTM	City Tie Module. 2-gang. Connection to a local energy fire alarm box.
MFC-A	Multifunction Fire Cabinet, 8" x 14" x 3.5" - red.
BC-1	Battery Cabinet. 14.0" x 18.25" x 7.25". Holds two 12V24A batteries.
BC-1R	Battery Cabinet - Red. 14.0" x 18.25" x 7.25". Holds two 12V24A batteries.
GSA-REL	Releasing Module
BC-1EQ	Seismic hardening Kit for VS Series panels. Includes battery hardening for BC-1 enclosure and components to harden panel internal components.

Programming Tools	
VS-CU	VS Series configuration and diagnostics utility.
260097	RS232 cable, 4 conductor, DB9 PC interface



Hoja de instalación del puente de servidor de campo SA-FSB

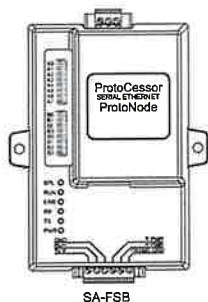

Descripción

El puente de servidor de campo (FSB) SA-FSB suministra un puente de comunicación entre los sistemas de seguridad de iO, VS y FX y los sistemas de gestión de edificios (BMS), convirtiendo el protocolo de comunicaciones externas del panel de control en protocolos de serie y Ethernet compatibles. La lista de los protocolos admitidos se encuentra en "Especificaciones" en la página 5.

Notas

- El SA-FSB está diseñado únicamente para el uso auxiliar. No se permite el uso en aplicaciones no auxiliares a menos que lo apruebe la autoridad local competente.
- El SA-FSB no se puede utilizar en aplicaciones de control de humo.

Aplicación

Esta sección describe las posibles aplicaciones de comunicación del SA-FSB entre un panel de control y un BMS. La programación, instalación y cableado del SA-FSB son iguales para cada aplicación.

Los paneles de control de iO, VS y FX son compatibles con un SA-FSB por panel de control. Cada SA-FSB se programa con los eventos de punto es responsable de enviar al BMS.

Número de puntos

Cada SA-FSB admite hasta 3.600 eventos de punto programados. El número total de eventos de punto programados se compone de los eventos de punto que ingresan al SA-FSB y de los eventos de punto que salen hacia el BMS.

Ejemplo: En el caso de un SA-FSB, se pueden programar 1.800 eventos de punto para que entren en el SA-FSB y hasta 1.800 eventos de punto para salir hacia el BMS.

Cuando calcule el número de puntos en su aplicación, tenga en cuenta que el total de eventos de punto programados admitidos se compone de dispositivos del panel (detector de humo, módulo, etc.) y tipos de eventos (alarma, problema, supervisión, etc.) y que un punto de dispositivo que informa al SA-FSB desde un panel, puede tener muchos puntos de tipo evento que salen al BMS.

Tareas necesarias

Las siguientes tareas son necesarias para preparar el SA-FSB para la comunicación entre el panel de control y un BMS.

1. Programar el SA-FSB (consulte "Programación" en la página 2).
2. Instalar el SA-FSB (consulte "Instalación" en la página 3).
3. Conecta el cableado de campo (consultar "Cableado" en la página 4).

Información básica

Antes de comenzar, asegúrese de que dispone de las siguientes herramientas:

- Una computadora con una tarjeta de interfaz de red.
- Un cable de conexión Ethernet RJ-45, Cat 5e o superior.
- Una lista de las direcciones de los dispositivos del sistema de seguridad de vida y sus posibles estados. Consulte la sección "Exportación de la lista de direcciones de dispositivos del Programa Utilitario de Configuración (CU) de iO, VS o FX" más adelante.
- Una conexión con el BMS.
- El archivo de configuración del SA-FSB (config.csv) para el protocolo utilizado por su BMS. El archivo de configuración predeterminado, Modbus TCP, se almacena en el SA-FSB. Otros protocolos pueden ser configurados y actualizados observando los pasos 6 y 7.

También necesitará los siguientes documentos que se pueden descargar del sitio web de MSA. Ingrese <https://us.msasafelv.com/smc> en su navegador y luego haga clic en el producto correspondiente en Featured Products (por ejemplo, ProtoNode). Cuando se abra la página del producto, haga clic en la pestaña Literature en la parte inferior de la página para ubicar el documento.

- [Start-Up Guide - ProtoNode](#)
- [Field Server Manual - FieldServer Toolbox and Graphic User Interface](#)
- [FieldServer Manual - FieldServer Configuration Guide](#)
- [Protocol Driver sheet - BACnet](#)
- [Protocol Driver sheet - M-BUS](#)
- [Protocol Driver sheet - DNP 3.0 Serial](#)

También es necesario el manual del panel alarma contra incendios FS-8705-47 iO, VS y FX, que puede descargarse de las siguientes páginas web.

Paneles iO y VS: Sitio web My-Eddie (<http://my-eddie.com/>)

Paneles de FX: Sitio web de FX (<http://kiddefx.kidde.com/>)

Exportación de la lista de direcciones de dispositivos del Programa Utilitario de Configuración (CU) de iO, VS o FX

Para programar las direcciones de los dispositivos en el archivo de configuración del SA-FSB, se necesita una lista de las direcciones de los dispositivos del sistema de seguridad de vida y los posibles estados de dichos dispositivos (por ejemplo, alarma, problema, etc.). Si no tiene la lista, puede exportarla del Programa Utilitario de Configuración (CU) de iO, VS o FX.

Para exportar la lista de direcciones de los dispositivos:

1. Cree un proyecto o abra un proyecto existente de iO, VS o FX CU.
2. Haga clic con el botón derecho en el menú Panel y, a continuación, haga clic en Exportar todos los eventos del sistema (FSB) (Export All System Events (FSB)).



3. Seleccione la ruta adecuada de acceso al archivo y, a continuación, haga clic en Exportar (Export) para exportar los datos del archivo CSV a la computadora. La ruta de acceso predeterminada es:

Nombre del proyecto > Nombre del panel >
All_System_Events.csv.

Programación

La velocidad de transferencia del campo está fijada en 9600. El ID de nodo y el protocolo se pueden ajustar en el archivo de configuración (consulte el Paso 6).

Paso 1: Descargue e instale la caja de herramientas de FieldServer

1. Ingrese <https://us.msasafety.com/smc> en su navegador y luego haga clic en ProtoNode en Featured Products. Cuando se abra la página del producto, en Additional Resources, haga clic en Software Downloads. Haga clic en FieldServer Toolbox.
2. Descomprima el archivo y haga doble clic en el archivo FieldServer Toolbox Setup.exe para instalar la caja de herramientas. La caja de herramientas se utilizará para crear un registro de diagnóstico que ayude a depurar la programación.

Paso 2: Encender el SA-FSB

1. Asegúrese de que el terminal Frame GND (FG) (conexión a tierra de la estructura) se utiliza para conectar la alimentación a tierra. Consulte "Cableado" en la página 4.
2. Conecte el cableado de alimentación desde los terminales de alimentación del SA-FSB en el conector HOST a los terminales de alimentación constante de 24 VCC del panel de control (COM y +) o a otra fuente de alimentación de 24 VCC. Consulte la Figura 5.

Paso 3: Confirme la conectividad del SA-FSB y conéctese a la interface de usuario del ProtoNode

1. Conecte un extremo del cable de red Ethernet a la toma Ethernet del SA-FSB y el otro extremo a la toma de la computadora.
2. Confirme la conectividad como se indica en Start-Up Guide - ProtoNode. (La dirección IP predeterminada del ProtoNode es 192.168.1.24, la máscara de subred es 255.255.255.0).

Paso 4: Modificar la configuración IP del SA-FSB

1. Abra el navegador de Internet (Chrome) e introduzca la dirección IP del SA-FSB (la dirección predeterminada es 192.168.1.24).
2. Expanda la carpeta de configuración en el árbol de navegación y luego haga clic en Configuración de Redes (Network Settings).
3. Introduzca la dirección IP, la máscara de subred y la puerta de enlace según la configuración de red existente.

Asegúrese de que la dirección IPv4 de su ordenador está en la misma red que el SA-FSB.
4. Haga clic en Reinicio del sistema (System Restart) para actualizar el archivo de configuración en el SA-FSB.

Paso 5: Cargar el archivo All_System_Events.csv en el SA-FSB

1. Abra el navegador de Internet (chrome) e introduzca la dirección IP del SA-FSB.
2. Expanda la carpeta configuración (Setup) en el árbol de navegación (Navigation Tree) y a continuación, haga clic en Transferencia de Archivos (File Transfer) y seleccione la pestaña General del archivo All_System_Events.csv desde la ubicación guardada correspondiente.
3. Elija el archivo y seleccione el botón Enviar (Submit).

Paso 6: Descargar la configuración del protocolo

Los eventos individuales de punto del sistema pueden ser transmitidos al BMS programando las direcciones de los dispositivos en el archivo de configuración del SA-FSB (config.csv).

1. Introduzca la siguiente URL en su navegador (Chrome) con la dirección IP configurada, por ejemplo: 192.168.1.24/iovsvx.html.
2. La página de configuración de IOVSFX FACP se abre como se muestra en la Figura 1.

Figura 1: Página de configuración de IOVSFX FACP

Offset	Parameters	Value
1	Language	0 English
2	Max Loops	4
3	Max Devices	250
4	BMS Protocol	5 - DNP3
5	BMS Node Id	1
6	BMS Mac Addr (MSTP Only)	0
7	Serve MultiState (M) objects to BMS	1
8	Serve Off Normal Binary (Bi) objects to BMS	1
9	Serve System Event data to BMS	1
10	Serve Zone data to BMS	1
11	Serve Annun data to BMS	1
12	Max Zone Number	100
13	Serve Alarms only*	0
14	Serve Supervisory only*	0
15	Serve Troubles only*	0
16	Serve Monitor only*	0

* Not available for DNP3

3. Seleccione el idioma de acuerdo a la configuración del iO, VS o FX CU (por ejemplo, inglés).
4. Introduzca el número máximo de lazos conectados según la configuración de su proyecto (por ejemplo, 4 lazos).
5. Introduzca el número máximo de dispositivos por lazo.
 - Paneles de iO y VS: 250 dispositivos
 - Panel de FX: 325 dispositivos
6. Seleccione el protocolo del BMS deseado (por ejemplo, Bacnet IP).

No existe soporte para la preferencia de estados de eventos específicos, solo el estado múltiple (MI) (Multi State) y estado binario (BI) (Binary State) son compatibles con DNP3.
7. Introduzca la zona Max en función del panel (16 para paneles de 64 puntos o 32 para paneles de 1.000 puntos).
8. Seleccione la(s) opción(es) adecuada(s) para recibir el tipo y la categoría de eventos que desea que el BMS reciba.
9. Si tiene preferencias específicas, seleccione cuidadosamente todos los tipos y categorías de eventos deseados. Se pueden seleccionar diversas opciones.
 - Servir los objetos normales binarios (Bi) al BMS (Serve Off Normal Binary objects) (ajustar al valor 1 si solo desea estados binarios y no el tipo de evento exacto)
 - Servir los datos de los eventos de sistema al BMS (Serve System Event data) (ajustar al valor 1 si desea que los eventos del sistema se envíen al BMS)
 - Servir los datos de Annun (anunciador) (Serve Annun data) al BMS (ajustar al valor 1 si desea que los eventos relacionados con el anunciador se envíen al BMS)
 - Servir los datos de zona al BMS (Serve Zone data) (ajustar al valor 1 si desea que los eventos relacionados con la zona se envíen al BMS)
 - Servir solo alarmas (Serve Alarms only) (ajustar al valor 1 si desea que los eventos de alarma se envíen al BMS)

- Servir solo supervisión (Serve Supervisory only) (ajustar al valor 1 si desea que los eventos de supervisión se envíen al BMS)
 - Servir solo problemas (Serve Troubles only) (ajustar al valor 1 si desea que los eventos de problemas se envíen al BMS)
 - Servir sólo a los monitores (Serve Monitor only) (ajustar el valor 1 si desea que los eventos de los monitores se envíen al BMS)
10. Para todos los protocolos del BMS, excepto el BACnet IP/MSTP, haga clic en Generar (Generate) y utilice la nueva configuración utilizando las etiquetas predeterminadas.
11. Para el protocolo BACnet IP/MSTP
- Si no existen preferencias de etiquetas, haga clic en Generar (Generate) y utilice la nueva configuración utilizando las etiquetas predeterminadas.
 - Si existen preferencias de etiquetas, vaya a Importar etiquetas (Import Labels) a partir de la configuración de FACP.
 - Haga clic en Elegir Archivo (Choose File) y seleccione el archivo All_System_Events.csv que recuperó previamente del programa utilitario de Configuración.
 - Haga clic en Enviar (Submit) y, a continuación, en Utilizar las etiquetas importadas, Generar (Using the Imported labels, Generate) y utilice la nueva configuración.

Nota: Si el nombre del archivo All_System_Events.csv tiene más de 40 caracteres, por favor, utilice un nombre de archivo de menos de 40 caracteres.

12. El mensaje IOVSFX Gateway se reiniciará en breve. Haga clic en Aceptar y el FSB se reiniciará.

Nota: Si no tiene ninguna preferencia específica, seleccione Servir objetos multiestado (Mi) (Serve MultiState objects) al BMS y ajuste el valor a 1.

Paso 7: Modificar el archivo de configuración

Para este paso, necesita la lista de direcciones de los dispositivos que desea programar en el archivo de configuración y el manual del protocolo que utiliza el BMS. Debe conocer el protocolo o tener acceso a alguien que lo conozca. También puede ser útil el FieldServer Manual - FieldServer Configuration Guide durante este paso.

En el paso 6, se ofrecen diversas opciones para generar el archivo de configuración. Además, si desea editar el archivo de configuración, siga los pasos siguientes.

1. Abra el navegador de Internet (Chrome) e introduzca la dirección IP del SA-FSB (la dirección predeterminada es 192.168.1.24).
2. Vaya a Configuración > Transferencia de archivos > Pestaña de configuración (Setup > FileTransfer > Configuration Tab).
 - a. Vaya a la sección Recuperar (Retrieve) y haga clic en config.csv.
 - b. Guarde el archivo en su computadora.
 - c. Elimine los eventos que no es necesario enviar al BMS y a continuación, guarde el archivo.
 - d. Cargue la configuración en el FSB mediante Actualizar configuración (Update Configuration). Elija el archivo actualizado y haga clic en enviar.
 - e. Haga clic en Reiniciar el sistema (System restart).
El FSB se reinicia y se carga la configuración deseada.

Paso 8: Desconecte el cable de red

1. Desconecte el cable de red Ethernet y la fuente de alimentación del SA-FSB.
2. Instale el SA-FSB, como se describe en Instalación.

Instalación

Instale y cablee este dispositivo según los códigos, las ordenanzas y las reglamentaciones locales y nacionales aplicables.

ADVERTENCIA: Peligro de electrocución. Para evitar lesiones personales, retire todas las fuentes de energía y deje que la energía almacenada se descargue antes de instalar o retirar el equipo.

El FSB se monta en un gabinete MFC-A equipado con FSB-BRKT2, ambos dispositivos se deben pedir por separado.

Para instalar el SA-FSB en un gabinete MFC-A:

1. Fije el SA-FSB al soporte de montaje FSB-BRKT2 utilizando las tuercas K de fijación suministradas. Consulte la Figura 2.
2. Instale el FSB-BRKT2 en el gabinete MFC-A utilizando dos tornillos # 6, como se muestra en la Figura 3.

El FSB-BRKT2 puede instalarse en el lado izquierdo o derecho del gabinete MFC-A.

Figura 2: Fijación del SA-FSB al soporte de montaje FSB-BRKT2

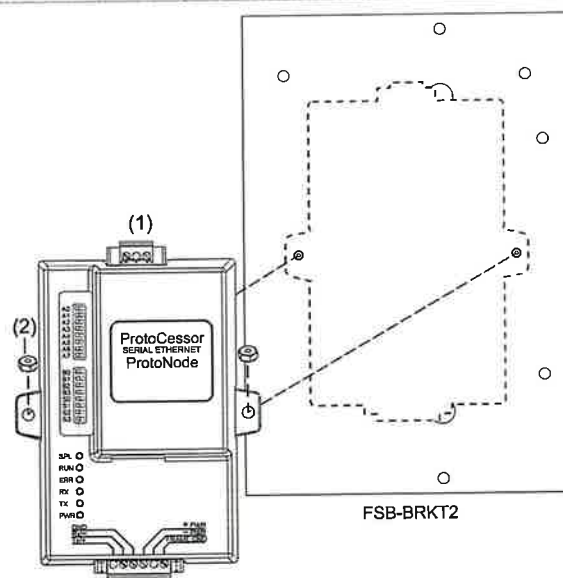

(1) SA-FSB

(2) Tuercas K de fijación #4 (2X)

Figura 3: Instalación del SA-FSB en un gabinete MFC-A

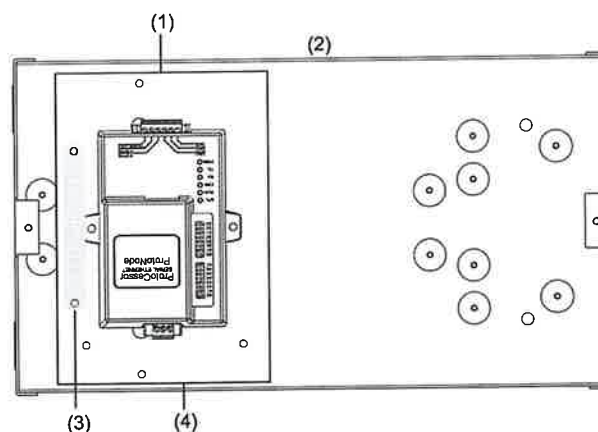

(1) Conector HOST en la parte superior
(2) Gabinete MFC-A

(3) Tornillo #6 (2X)
(4) FSB-BRKT2

Cableado

El SA-FSB se alimenta de los puertos AUX1 o AUX2 de la placa electrónica del panel de control o de una fuente de alimentación regulada de 24 V CC compatible, homologada por UL/ULC para sistemas de señalización de protección contra incendios.

Se comunica con el panel a través de una conexión RS-232, utilizando la placa opcional SA-232. Se comunica con el BMS a través de una conexión RS-485 o Ethernet como se muestra en la Figura 4 y Figura 5.

Notas

- Seleccione FSB no supervisado (FSB Unsupervised) en la CU. La velocidad de transferencia del campo está fijada en 9600.
- En el caso de terminales de alimentación, asegúrese de que el terminal Frame GND (FG) (conexión a tierra de la estructura) se utiliza para conectar a tierra la alimentación eléctrica. Coloque el gabinete MFC-A que aloja el SA-FSB a menos de 6,1 m (20 pies) del panel y encierre el cableado en un conducto.
- Para el cableado RS-232, la longitud máxima del circuito es de 6,1 m (20 pies).

Para cablear el SA-FSB:

1. Conecte el cableado de alimentación a los terminales de alimentación del SA-FSB en el conector HOST y a los terminales de alimentación AUX en el panel. Consulte la Figura 5.
2. Conecte el cableado RS-485 al conector SA-FSB FIELD y a la conexión RS-485 del BMS, como se muestra en la Figura 4.

— o —

Conecte el cable Ethernet a la toma ETHERNET del SA-FSB y a la conexión de red del BMS, como se muestra en la Figura 5.

3. Conecte el cableado RS-232 a los terminales RS-232 del SA-FSB en el conector HOST y a los terminales RS-232 de la placa SA-232. Consulte la *Hoja de instalación de la tarjeta de interfaz SA-232 RS-232*, (P/N 3101095). Consulte la Figura 5.

Figura 4: Cableado de las conexiones RS-485 del SA-FSB

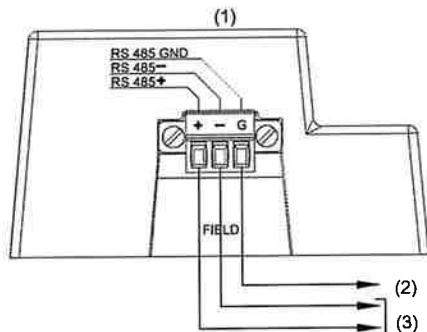

- (1) Conector SA-FSB RS-485
 (2) Conexión a tierra
 (3) Al RS-485 del BMS

Figura 5: Cableado de las conexiones RS-232, de alimentación y Ethernet del SA-FSB

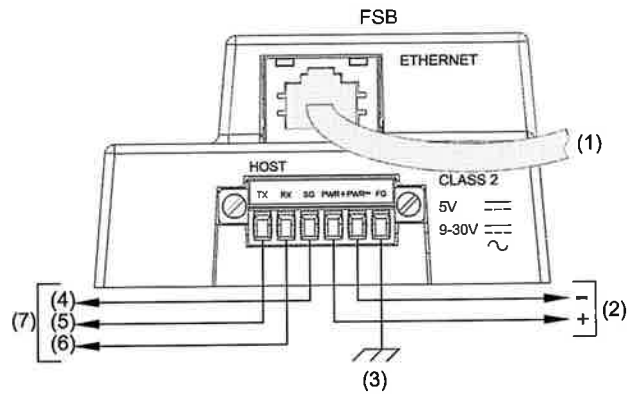

- (1) A Ethernet del BMS
 (2) A la alimentación AUX
 (3) Conexión a tierra de la estructura
 (4) COM
 (5) RX
 (6) TX
 (7) A las conexiones RS-232 de la placa SA-232

Notas

- La alimentación del panel de control se realiza desde los terminales AUX1 o AUX2 24+/C de la placa electrónica del panel o de una fuente de alimentación regulada de 24 VCC compatible que esté homologada por la normativa UL/ULC para sistemas de señalización de protección contra incendios.
- Configure la alimentación de AUX2 en la CU o utilizando la programación del panel frontal configurada como no reajutable. Consulte la Ayuda de la CU o la Referencia Técnica para más obtener más detalles.

Prueba

Pruebe la comunicación entre el panel de control y el BMS para asegurarse de que se transmiten los puntos de evento deseados.

Notas

- Para un SA-FSB, puede encontrar las descripciones de LED en la Start-Up Guide - ProtoNode.
- Para un SA-FSB, se puede probar rápidamente BACnet/IP o BACnet MS/TP utilizando el BACnet Explorer (adquirido por separado en www.sierramonitor.com/connect/fieldserver-products/bacnet-explorer).

Para probar la comunicación entre el panel de control y el BMS:

1. En el panel de control, inicie un evento de punto que haya programado para ser enviado desde el SA-FSB al BMS.
2. Desde la interfaz de usuario de ProtoNode, introduzca O y verifique que el mensaje de evento fue transmitido al BMS correctamente. (Consulte el *manual de la interfaz gráfica de usuario de FieldServer (FS-GUI)* para obtener detalles sobre el uso de la GUI).
3. Restaurar el evento de punto.
4. Pruebe otros puntos según sea necesario.

Especificaciones

Voltaje	9 a 30 VDC (de la fuente de alimentación del panel de control o desde una fuente de alimentación de 24 VDC homologada por la normativa UL/ULC para sistemas de señalización de protección contra incendios)
Corriente SA-FSB	120 mA máx. (a 24 VDC)
Interfaces de comunicación SA-FSB□ Serial	RS-232 mediante placa opcional SA-232
Sistemas compatibles	iO, VS y FX con CU y firmware de panel versión 4.3 o posterior
Gabinetes compatibles	MFC-A
Montaje	FSB-BRKT2
Protocolos compatibles SA-FSB a serial	Modbus RTU, BACnet MS/TP
SA-FSB a Ethernet	Modbus TCP (predeterminado), BACnet/IP, DNP Ethernet
Flujo de señales	Una vía solamente desde el panel, al SA-FSB, al BMS
Puntos [1] SA-FSB	3.600 máx.
Número de SA-FSB iO, VS y FX	1 máx.
Longitud del circuito RS-232	6,1 m (20 pies) como máximo.
Dimensiones (ancho × alto × profundidad) FSB-BRKT2	4,85 × 7,13 × 0,05 pulg. (12,32 × 18,11 × 0,13 cm)
SA-FSB	3,63 × 5,00 × 1,63 pulg. (9,22 × 12,70 × 4,14 cm)
Entorno de funcionamiento Temperatura	De 0 a 49°C (32 a 120°F)
Humedad relativa	0 a 93% sin condensación

[1] Consulte Número de puntos.

Información sobre reglamentaciones

Para obtener información sobre normativas, consulte el documento FieldServer Data Sheet - ProtoNode. La hoja de datos se puede descargar del sitio web de MSA.

Ingrese <https://us.msasafety.com/smc> en su navegador y luego haga clic en ProtoNode en Featured Products. En la página ProtoNode, haga clic en la pestaña Literature en la parte inferior de la página y luego haga clic en FieldServer Data Sheet - ProtoNode.

Información de contacto

Para obtener información de contacto, consulte a:

Edwards: www.edwardsfiresafety.com

Kidde: www.kidde-esfire.com



Technology that saves lives

Manual Pull Stations

GSA-M270, GSA-M270P,
GSA-M278



Overview

The GSA-M270 and GSA-M278 series Manual Pull Stations are part of Kidde's Signature Series system. The GSA-M270 Fire Alarm Manual Pull Stations feature our very familiar teardrop shape. They are made from die-cast zinc and finished with red epoxy powder-coat paint complemented by aluminum colored stripes and markings. With positive pull-lever operation, one pull on the station handle breaks the glass rod and turns in a positive alarm, ensuring protection plus fool-proof operation. Presignal models (GSA-M270P) are equipped with a general alarm (GA) keyswitch for applications where two stage operation is required. The up-front highly visible glass rod discourages tampering, but is not required for proper operation.

Kidde's double action single stage GSA-M278 station is a contemporary style manual station made from durable red colored lexan. To initiate an alarm, first lift the upper door marked "LIFT THEN PULL HANDLE", then pull the alarm handle.

Standard Features

Note: Some features described here may not be supported by all control systems. Check your control panel's Installation and Operation Guide for details.

- **Traditional familiar appearance**
GSA-M270 models feature our familiar teardrop design with simple positive pull action and sturdy die-cast metal body.
- **One stage (GA), two stage (pre-signal), and double action models**
GSA-M270 models are available for one or two stage alarm systems. The single stage double action GSA-M278 features a rugged Lexan housing with keyed reset mechanism.

- **Break glass operation**
An up-front visible glass rod on the GSA-M270 discourages tampering.
- **Intelligent device with integral microprocessor**
All decisions are made at the station allowing lower communication speed while substantially improving control panel response time. Less sensitive to line noise and loop wiring properties; twisted or shielded wire is not required.
- **ADA Compliant**
Meets ADA requirements for manual pull stations.
- **Electronic Addressing with Non-volatile memory**
Permanently stores programmable address, serial number, type of device, and job number. Automatically updates historic information including hours of operation, last maintenance date, number of alarms and troubles, and time and date of last alarm.
- **Automatic device mapping**
Each station transmits wiring information to the loop controller regarding its location with respect to other devices on the circuit.
- **Stand-alone operation**
The station inputs an alarm even if the loop controller's polling interrogation stops.
- **Diagnostic LEDs**
Status LEDs; flashing GREEN shows normal polling; flashing RED shows alarm state.
- **Designed for high ambient temperature operation**
Install in ambient temperatures up to 120 °F (49 °C).

Application

The operating characteristics of the fire alarm stations are determined by their sub-type code or "Personality Code". NORMALLY-OPEN ALARM - LATCHING (Personality Code 1) is assigned by the factory; no user configuration is required. The device is configured for Class B IDC operation. An ALARM signal is sent to the loop controller when the station's pull lever is operated. The alarm condition is latched at the station.

Compatibility

Signature Series manual stations are compatible only with Kidde's Signature Loop Controller.

Warnings & Cautions

This device will not operate without electrical power. As fires frequently cause power interruption, we suggest you discuss further safeguards with your local fire protection specialist.

Testing & Maintenance

To test (or reset) the station simply open the station and operate the exposed switch. The GSA-M270 series are opened with a tool; the GSA-M278 requires the key which is supplied with that station.

The station's automatic self-diagnosis identifies when it is defective and causes a trouble message. The user-friendly maintenance program shows the current state of each Signature series device and other pertinent messages. Single devices may be deactivated temporarily, from the control panel. Availability of maintenance features is dependent on the fire alarm system used.

Scheduled maintenance (Regular or Selected) for proper system operation should be planned to meet the requirements of the Authority Having Jurisdiction (AHJ). Refer to current NFPA 72 and ULC CAN/ULC 536 standards.

Typical Wiring

The fire alarm station's terminal block accepts #18 AWG (0.75mm²) to #12 AWG (2.5mm²) wire sizes. See Signature Loop Controller catalog sheet for detailed wiring requirement specifications.

Wiring Notes

1. Refer to Signature Loop Controller manual for maximum wire distance.
2. All wiring is power limited and supervised.

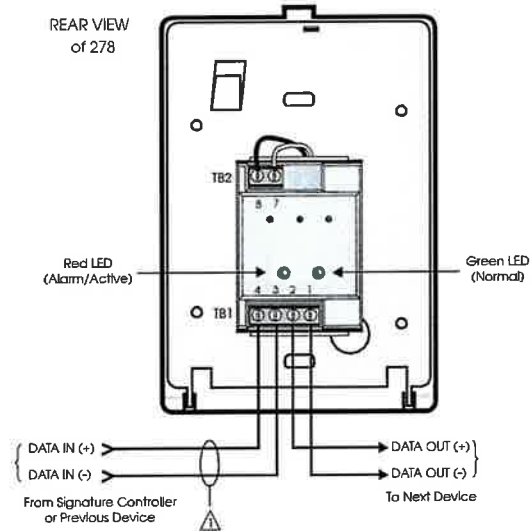

Figure 4. Single Stage Systems

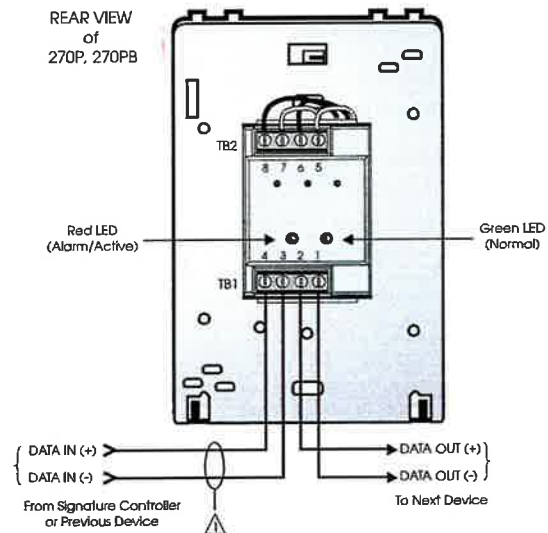

Figure 5. Two Stage Systems

Installation

Single-stage Signature Series fire alarm manual pull stations mount to North American 2½ inch (64 mm) deep 1-gang boxes.

Two stage presignal (270P) models require 1½ inch (38 mm) deep 4-inch square boxes with 1-gang, ½-inch raised covers. Openings must be angular. *Rounded openings are not acceptable.* Recommended box: Steel City Model 52-C-13; in Canada, use Iberville Model CI-52-C-49-1/2.

All models include terminals are suited for #12 to #18 AWG (2.5 mm² to 0.75 mm²) wire size. Kidde recommends that these fire alarm stations be installed according to latest recognized edition of national and local fire alarm codes.

Electronic Addressing: The loop controller electronically addresses each manual station, saving valuable time during system commissioning. Setting complicated switches or dials is not required. Each station has its own unique serial number stored in its on-board memory. The loop controller identifies each device on the loop and assigns a "soft" address to each serial number. If desired, the stations can be addressed using the SIGA-PRO Signature Program/Service Tool.

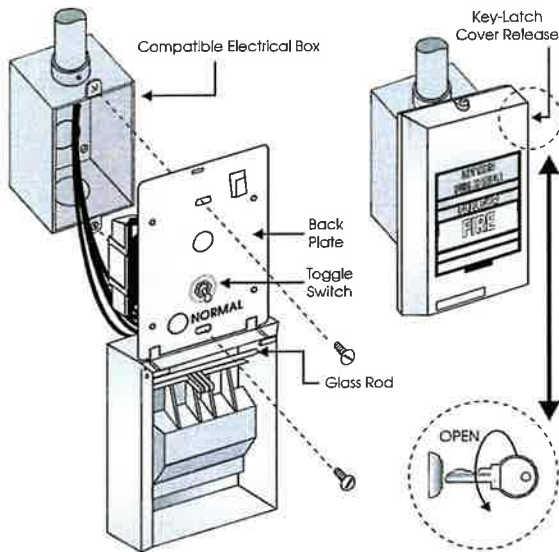

Figure 1. GSA-M278 installation

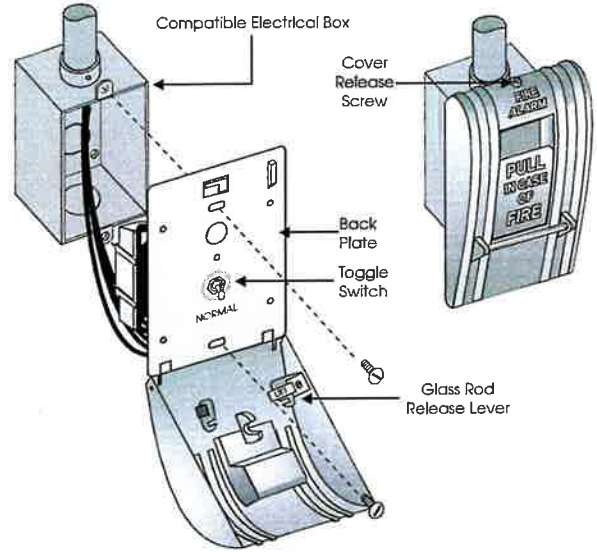

Figure 2. GSA-M270 installation

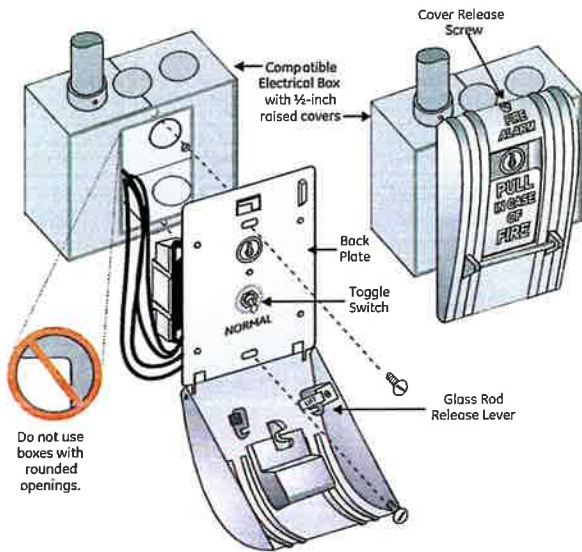

Figure 3. GSA-M270P installation



Technology that saves lives

Contact us...

Email: kidde.fire@fs.utc.com
 Web: kidde.com/engineeredsystems

1016 Corporate Park Drive
 Mebane, NC 27302

Kidde is a registered mark in the United States and other countries.

© 2018 Walter Kidde Portable Equipment. All rights reserved.

Specifications

Catalog Number	GSA-M270	GSA-M270P	GSA-M278
Description	Single Action - One Stage	Single Action - Two Stage (Presignal)	Double Action - One Stage
Addressing Requirements	Uses 1 Module Address	Uses 2 Module Addresses	Uses 1 Module Address
Operating Current	Standby = 250µA Activated = 400µA	Standby = 396µA Activated = 680µA	Standby = 250µA Activated = 400µA
Construction & Finish	Diecast Zinc - Red Epoxy with aluminum markings		Lexan - Red with white markings
Type Code	Factory Set		
Operating Voltage	15.2 to 19.95 Vdc (19 Vdc nominal)		
Storage and Operating Environment	Operating Temperature: 32°F to 120°F (0°C to 49°C) Storage Temperature: -4°F to 140°F (-20°C to 60°C) Humidity: 0 to 93% RH		
LED Operation	On-board Green LED - Flashes when polled On-board Red LED - Flashes when in alarm		
Compatibility	Use With: Signature Loop Controller		
Agency Listings	UL, ULC, MEA, CSFM, FM		

Ordering Information

Catalog Number	Description	Ship Wt. lbs (kg)
GSA-M270	One Stage Fire Alarm Station, English Markings - UL/ULC Listed	
GSA-M270P	Two Stage (Presignal) Fire Alarm Station, English Markings - UL/ULC Listed	1 (0.5)
GSA-M278	Double Action (One Stage) Fire Alarm Station, English Markings - UL/ULC Listed	
Accessories		
270-GLR	20 Glass Rods - for GSA-M270 series (USA ONLY)	
276-GLR	20 Glass Rods - for GSA-M278 series	



Inteligente Detectores de calor

KI-HRD, KI-HFD



Descripción general

El KI Serie humo detectores traen avanzado detección tecnología a a práctico diseño eso aumenta eficiencia, ahorra instalación tiempo, recortes costos, y se extiende propiedad protección capacidades. Continuo autodiagnóstico asegurar fiabilidad encima el de larga distancia, mientras el el último termistor tecnología marcas estos detectores Ideal para cualquier lugar donde se requiera una detección de calor fiable.

El KI-HRD es un detector de incendios inteligente de temperatura fija/velocidad de aumento. Monitoriza la temperatura del aire circundante y la analiza. el datos de el sensor a determinar si a Activar una alarma. La función de detección de la velocidad de aumento de temperatura detecta rápidamente un incendio rápido y con llamas. fuego. El temperatura fija calor función detecta fuego cuando la temperatura del aire cerca del detector supera el punto de alarma.

El KI-HFD es un inteligente temperatura fija calor detector que contiene a temperatura fija calor sensor calificado en 135 °F (57.2 °C). Él hace no tener a tasa de aumento función. El calor sensor monitores el temperatura de el aire en es alrededores y el El detector analiza el datos a determinar cuando el aire temperatura cerca El detector supera el punto de alarma del dispositivo.

Estándar Características

Nota: Alguno características descrito aquí puede no ser apoyado por todos control sistemas. Controlar su control panel Instalación y la Guía de Operación para obtener más detalles.

- Próximo generación calor detección tecnología
- 135 °F (57 °C) fijado temperatura alarma punto (Desarrollo de Recursos Humanos) y HFD)
- 15 °F (8.3 °C) por minuto tasa de aumento alarma punto (RRHH)
- Usos existente alambrado
- Automático dispositivo cartografía
- Sensor Marcas Proporcionar Fácil Pruebas Identificación
- Arriba a 250 total dispositivos por bucle
- No volátil memoria
- direccionamiento electrónico
- Bicolor (verde/rojo) estado CONDUJO
- Cubrir calificación para fácil identificación durante pruebas
- Estándar, relé, falla aislador, y audible montaje bases
- 50 pie (15.2 metro) espaciado

Solicitud

El KI-HRD combinación fijado temperatura/tasa de aumento calor detector proporciona a 15 °F (9 °C) por minuto tasa de aumento calor sensor para el detección de de rápido desarrollo incendios, como Bueno como a 135 °F (57 °C) fijo temperatura sensor para lento incendios de edificios. El KI-HFD temperatura fija detector proporciona a 135 °F (57°C) fijado Sensor de temperatura para incendios de edificios de propagación lenta.

Compatibilidad

El KI-HRD detector es compatible con Kidde VS y Máquina virtual paneles de la serie.

Instalación

Bases de montaje para detectores de la serie KI Norte Americano 1-banco cajas, cajas octogonales de 3-1/2 pulgadas o 4 pulgadas, y hasta cajas eléctricas cuadradas de 4 pulgadas cajas 1-1/2 pulgadas (38 mm de profundidad). Se montan en el sistema BESA europeo. y 1-banco cajas con Distancia entre centros de fijación: 60,3 mm. Consulte la sección de instalación y cableado de la base de montaje para obtener más información.

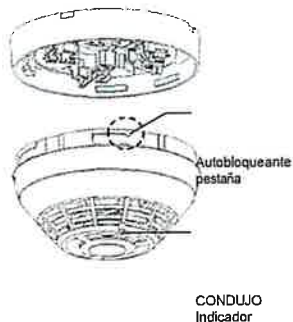

Accesorios

Detector montaje bases tener alambrado terminales eso son accesible de el "lado de la habitación" después montaje el base a el Caja eléctrica . Las bases se montan en cajas de 1 módulo norteamericanas y en cajas de 3½. pulgada o 4 pulgada octágono cajas, 1½ pulgadas (38 mm) profundo. También se pueden instalar en cajas BESA europeas y cajas de un módulo con centros de fijación de 60,3 mm. Los modelos KI-SB4, KI-RB4 y KI-IB4 se pueden instalar en cajas eléctricas cuadradas de 4 pulgadas norteamericanas, además de en las cajas mencionadas anteriormente. Ellos incluir el GSA-TS4 Recortar Falda, cual es usado para cubrir el "montaje orejas" en el base. El KI-ABST soportes a Solo una caja cuadrada de 4 pulgadas.



Remoto CONDUJO GSA-LED - El remoto CONDUJO conecta a el KI-SB o KI-SB4 Estándar Base solo. Él características a Norte Americano tamaño 1-banda plástico placa frontal con a blanco finalizar y rojo alarma CONDUJO.

GSA-TS4 Recortar Falda - Suministrado con 4 pulgada bases, él poder también ser ordenado por separado a usar con el otro bases a ayuda ocultar las imperfecciones de la superficie que no cubren las bases más pequeñas.

Sonda Bases - KI Serie sonor bases son diseñado para usar donde localizado o grupo alarma señalización es requerido.

- Las bases KI-ABST proporcionan capacidad de sirena a los detectores de humo y calor de la serie KI. No están diseñadas para su uso con combinación carbón monóxido detectores en Modo fuego más CO.
- KI-ABDT bases proporcionar sonor capacidad a KI Serie humo y calor detectores, como Bueno como carbón detectores de monóxido cuando usado con a GSA-T3T4 Temporal Generador de patrones.
- Las bases KI-ABLT proporcionan capacidad de sondeo de baja frecuencia de 520 Hz. a KI Serie fumar y calor detectores, como Bueno como detectores de monóxido de carbono cuando se utilizan con un GSA-T3T4 Temporal Patrón Generador. El KI-ABLT es adecuado para aplicaciones que requieren tonos audibles de baja frecuencia.

Percepción y informes tecnología

El microprocesador en cada detector proporciona adicional beneficios - Autodiagnóstico y Historia Registro, Automático Dispositivo Cartografía, y una comunicación rápida y estable.

Autodiagnóstico y registro histórico : cada detector de la serie KI constantemente corre autoevaluaciones a proporcionar importante mantenimiento información . El resultados de el autocomprobación son automáticamente Actualizado y almacenado permanentemente en la memoria no volátil del detector.

Asignación automática de dispositivos : el controlador de bucle aprende dónde se encuentra cada dispositivo. dispositivos de serie número DIRECCIÓN es instalado relativo a otros dispositivos en el circuito. El cartografía característica proporciona supervisión de cada dispositivos instalado ubicación a prevenir a detector de se está reinstalando (después limpieza etc.) en a diferente ubicación de dónde Originalmente lo era.

Rápido Comunicación estable : la inteligencia integrada reduce la cantidad de información que se necesita enviar entre el detector y el controlador de bucle. Otro que regular de supervisor votación respuesta, el detector solo necesidades a comunicar con el bucle controlador cuando tiene algo nuevo que informar.

Advertencias y Precauciones

- Este detector no funciona sin alimentación eléctrica. En caso de incendios frecuentemente causa fuerza interrupción, conversar más medidas de seguridad con el especialista local en protección contra incendios.
- Este detector hace no sentido incendios en áreas dónde calor El calor procedente de incendios en paredes, techos o al otro lado de puertas cerradas puede no llegar al detector.
- Este calor detector por sí mismo hace no proporcionar vida seguridad Protección . Utilice este detector con detectores de humo de ionización y/o fotoeléctricos.
- Este detector no detecta niveles de oxígeno, humo ni gases tóxicos. o llamas. Usar este dispositivo como parte de a vida de base amplia seguridad programa cual incluye a variedad de fuentes de información perteneciente a calor y fumar niveles, sistemas de extinción , visual y audible

dispositivos, y otras medidas de seguridad.

- Independientemente de los estudios, los detectores de calor deberían solo utilizarse cuando se trate

exclusivamente de la protección de la propiedad. Nunca confíe en los detectores de calor como único medio de protección contra incendios.

Típico Alambrado

Las bases de montaje del detector aceptan cable n.º 18 AWG (0,75 mm²), n.º 16 (1,0 mm²), #14 AWG (1,5 mm²), y #12 AWG (2,5 mm²) cable tamaños. Tamaños #16 AWG (1,0 mm²) y #18 AWG (0,75 mm²) son Preferible por su facilidad de instalación.

Estándar Detector Base, KI-SB, KI-SB4

Este es el básico montaje Base para detectores Kidde de la serie KI. GSA-LED Remoto CONDUJO está respaldado por esto Base.

Term	Description
1	Not Used
2	DATA IN/OUT (+)
3	Not Used
4	DATA IN (-)
4	Remote LED (-)
5	Remote LED (+)
6	Not Used
7	DATA OUT (-)

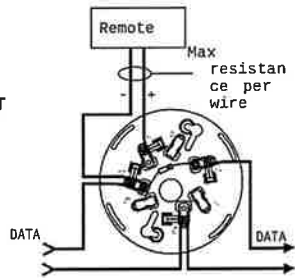

DATOS EN (+) De Firma Controlador dispositivo anterior

DATOS AFUERA (-) A Próximo Dispositivo

Relé Detector Base, KI-RB, KI-RB4

Este base incluye a relé. Normalmente Abierto o Normalmente Durante la instalación se selecciona el funcionamiento en modo cerrado. El contacto seco está clasificado para 1 amperio (piloto deber) @ 30 Vcc. El relevo posición está supervisado a evitar sacudida accidental él afuera de posición. El KI-RB puede funcionar como un relé de control si se programa para ello en el control panel. El relé La base no es compatible con el GSA-LED. Remoto LED.

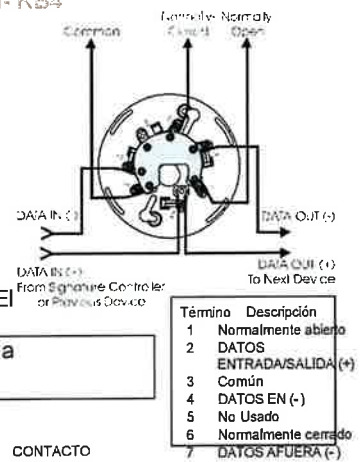

1.0 Amperio @ 30 VDC (Piloto Deber)

Audible Sonda Bases, Fuego Modo

ABDT, ABST, ABLT sonor bases

Aislador Detector Base, KI-IB, KI-IB4

Este base incluye a incorporado línea falla aislador para usar en Clase Un circuito. A detector debe ser instalado para él a funcionar. El La base del aislador no es compatible con el LED remoto GSA-LED.

El aislador opera como sigue:

- a corto en el línea causas todo Los aisladores se abrirán en 23 ms
- a intervalos de 10 ms, comenzando en uno lado de la Clase A circuito más cercano el controlador de bucle, el aisladores cercanos para proporcionar el siguiente aislador abajo el línea con fuerza
- cuando el aislador próximo a el corto cierra, él reabre dentro 10 mseg.

El proceso repeticiones comienzo en el otro lado del controlador de bucle.

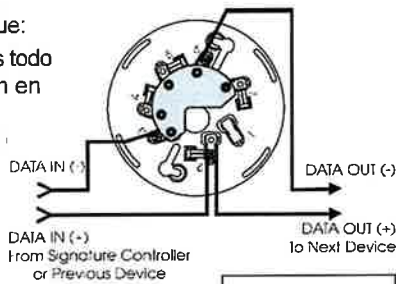

Término	Descripción
1	No Usado
2	DATOS ENTRADA/SALIDA (+)
3	DATOS EN (-)
4	No Usado
5	No Usado
6	DATOS AFUERA (-)
7	No Usado

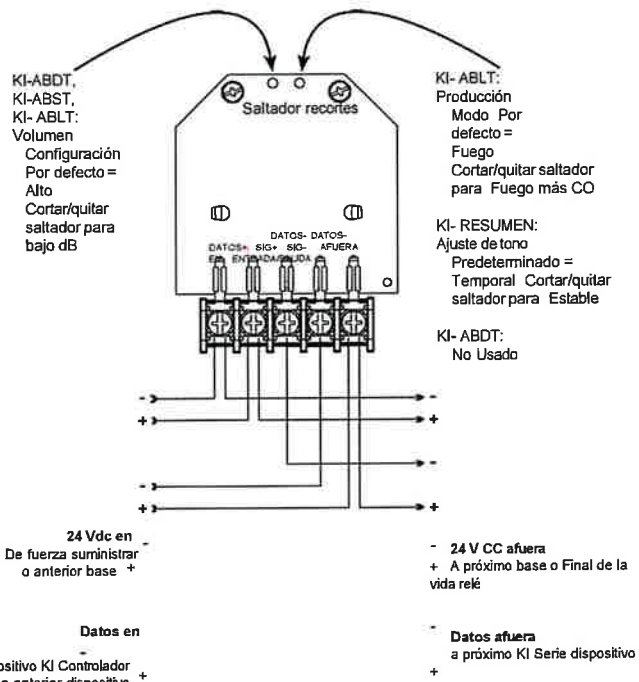



Tecnología eso ahorra vidas

Contacto a nosotros...

Correo electrónico: kidde.fire@fs.utc.com
 Web: kidde.com/sistemas de ingeniería

1016 Corporativo Parque Conducir
 Mebane, NC 27302

Kidde es a registrado marca en el Unido
 Estados y otros países.

© 2018 Walter Kidde Portátil Equipo.
 Reservados todos los derechos.

Dimensiones



Presupuesto

	KI- HRD	KI-HFD
Tensión de funcionamiento	15,20 a 19,95	
Corriente de funcionamiento normal	VDC 51 µA	
Alarma actual	68 µA	
Nivel de vibración	10 a 35 Hz, con un amplitud de 0,01	
Velocidad de calentamiento:	15 °F/min (8 °C/min)	
NA		
Temperatura fija nominal	de 135 °F (57,2 °C). Actual alarma punto 129 a 141°F (53.9 a 60,6 °C). Espaciamiento máximo de	
Compatible bases	50 pies (15,2 m) entre centros Ver Pedidos Información	
Compatible detector	Probadores Testifire 1000, Testifire Testifire 2000	2000
Entorno operativo	32 a 100°F (0 a 38°C), 0 a 93% RH, Polímero de ingeniería de alto impacto para construcción , sin condensación , blanco.	
Temperatura de almacenamiento:	-4 a 140 °F (-20 a 60 °C).	
Agencia Listados	CAN/ULC-S530, UL 521	CAN/ULC-S530-M91, UL 521

Pedidos Información

Catalog Number	Description	Ship Wt. lbs (kg)
KI-HRD	Intelligent fixed temperature/Rate-of-rise heat detector	0.4 (0.16)
KI-HFD	Intelligent fixed temperature heat detector	

Compatible Bases

Compatible Bases	Description	Ship Wt. lbs (kg)
KI-SB	Detector Mounting Base - Standard	
KI-SB4	4-inch Detector Mounting Base c/w Trim Skirt	
KI-RB	Detector Mounting Base w/Relay	0.2 (.09)
KI-RB4	4-inch Detector Mounting Base w/Relay, c/w Trim Skirt	
KI-IB	Detector Mounting Base w/Fault Isolator	
KI-IB4	4-inch Detector Mounting Base w/ Fault Isolator, c/w Trim Skirt	
KI-ABST	Audible (Sounder) Base for Fire Detectors	
KI-ABLT	Low Frequency Audible (Sounder) Base for CO and Fire Detectors	0.3 (0.15)
KI-ABDT	Audible (Sounder) Base for CO and Fire Detectors	
GSA-LED	Remote Alarm LED (not for EN54 applications)	
GSA-TS4	Trim Skirt (supplied with 4-inch bases)	0.1 (0.04)
GSA-TS	Trim Skirt (optional for non 4-inch bases)	

Fire Alarm Unshielded Cable Riser

-GENESIS-

Genesis Fire Alarm Cables ensure uninterrupted fire protection. Built to exceed the demands of rigorous fire safety codes and regulations, UL listed, and Made in the USA.

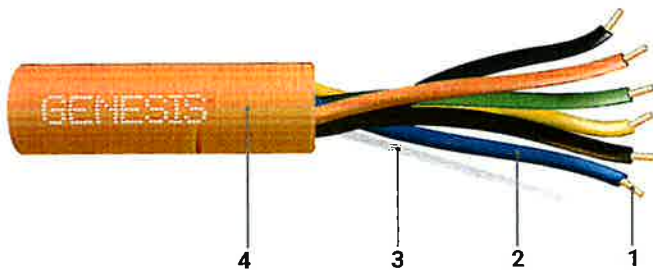

Construction

1. **Conductor:** Bare Copper conductors for excellent conductivity and low voltage drop
2. **Insulation:** Polypropylene
3. **Rip Cord:** Durable rip cord for efficient jacket stripping and removal
4. **Jacket:** PVC
Countdown® Length Markings for easy tracking of usage and remaining cable

Applications

- Installed in a metal raceway that complies with 300.22(B)
- Supported by solid bottom metal cable trays with solid metal covers
- In risers
- Within buildings in other than air-handling spaces and risers
- Exposed to sunlight

Specifications

- UL 1666 – Riser Rated
- UL 444 – Communication Cables, Type CMR (22 AWG – 16 AWG)
- UL 1424 – Cables for Power-Limited Fire-Alarm Circuits, Type FPLR
- UL 13 – Power-Limited Circuit Cables, Type CL3R
- Sunlight Resistant Rated
- REACH/RoHS Compliant
- Rated for 300 Volts
- Rated for -20°C to 75°C

Conductor Color Codes: Fire Alarm Cable

Conductor Number	Color
1	Black
2	Red
3	Green
4	Yellow
5	Brown
6	Blue

Sample Print Legend

GENESIS P/N 43XX XC XXAWG E175105 (UL) FPLR OR CL3R OR CMR C(UL)US SUN RES 75C
(RoHS) W/O #XXXXXX-XXXXXX XXXX FT DEVICE/ZONE A B C D E F 1 2 3 4 5 6 7 8 9

Fire Alarm Unshielded Cable, Riser

Part Number	Conductor Size (AWG)	Number of Conductors	Stranding	Insulation Thickness (in.)	Jacket Thickness (in.)	Nominal Diameter (in.)	DC Resistance (Ohms/1000 ft. at 20 °C)	Capacitance (pF/ft.)	Weight (lbs./1000ft.)
4301	22	4	Solid	0.006	0.015	0.117	18	18.8	11.3
4302	22	6	Solid	0.006	0.015	0.132	18	18.8	15.9
4306	18	2	Solid	0.006	0.015	0.134	6.52	22.8	14.1
4307	18	4	Solid	0.006	0.015	0.155	6.52	22.8	25.3
4308	18	6	Solid	0.006	0.017	0.180	6.52	22.8	37.1
4311	16	2	Solid	0.006	0.017	0.167	4.1	22.3	22.1
4312	16	4	Solid	0.006	0.018	0.197	4.1	22.3	40.2
4313	14	2	Solid	0.006	0.018	0.196	2.57	24.1	33.3
4314	14	4	Solid	0.006	0.020	0.233	2.57	24.1	62.0
4315	12	2	Solid	0.006	0.020	0.235	1.62	25.9	50.7
4320	12	2	65-strand	0.006	0.020	0.262	1.65	24.9	53.2

Genesis Cable
 7701 95th Street
 Pleasant Prairie, WI 53158
 Office: 800.222.0060
 www.genescable.com



-GENESIS-

**Sunlite 05269-SU Compact LED
Emergency Light Fixture, 2 Watts, 120-
277 Volt, Dual Heads, 90-Minute Battery
Backup, Wall or Ceiling Mount, IP20, UL
Listed, White**

**COMPACT SIZE DUAL HEAD EMERGENCY
LIGHT**

DESCRIPTION:

The Sunlite LED compact emergency light will help guide you to safety in the event of a power outage. Built-in back up batteries charge automatically when power is on and provide up to 90 minutes of light when the power is out. It features a flame-retardant, high impact thermoplastic housing molded in white. Each of the two lights can be positioned independently to provide optimum coverage. Built-in test switch and LED status indicator light. Bright 200 lumen output at 6500K daylight color temperature. Designed for wall or ceiling mounting on 120-277V service. UL Listed and CEC Title 20 compliant. IP20 rated.

FEATURES:

- **COMPACT EMERGENCY LIGHTING** - The Sunlite LED emergency light will help guide you to safety in the event of a power outage. They activate automatically and each of the two lights can be positioned independently to provide optimum coverage.
- **INTEGRATED LEDS** - With energy efficient LED technology built-in this is a maintenance free solution.
- **90 MINUTE BACK UP** - Built-in back up batteries charge automatically when power is on and provide up to 90 minutes of light when the power is out. Built-in test switch and LED status indicator light.
- **WALL OR CEILING MOUNT** - Designed for wall or ceiling mounting on 120-277V service. It features a flame-retardant, high impact thermoplastic housing molded in white.
- **SAFETY RATED** - UL Listed and CEC Title 20 compliant. IP20 rated.



SPECIFICATIONS:

General Characteristics

Finish	White
Material	Plastic
Lens	2 Head
Lens Material	Plastic

Electrical Characteristics

Watts	2
Volts	120-277

Light Characteristics

Lumens Brightness	200
Color Rendering Index CRI	70
Emitted Color	Daylight
Color Temperature Kelvin	6500K

Fixture Characteristics

Number of Lights	2
Mounting	Wall
Fixture Technology	EXIT
Use Location	Indoor

Additional Features

Safety Rating Mark	UL Listed - Damp Location
---------------------------	---------------------------

Product Dimensions

Item Dimension (in)	(W) 6.29 (H) 3.93 (D) 1.77
Package Dimension (in)	(W) 4.4 (H) 2.1 (D) 8.9
Package Weight (lb)	0.800

Product Data

Case Unit Rate	12
Item UPC	653703052694
Warranty Years	2



LIFE SAFETY SOLUTIONS

Genesis LED G1 Series

Compact Notification Devices



Overview

Genesis LED G1 Series horns and LED strobes feature a sleek low profile design and energy-efficient technology that makes them less expensive to install and operate by reducing overhead. High performance LEDs require fewer circuits and power supplies. These new appliances are designed with energy-efficiency and life safety in mind.

Genesis LED G1 Series uses high efficiency optics, combined with patented electronics, to deliver a highly controlled and efficiently focused light distribution pattern in exchange for lower current requirements. Strobes feature field-selectable 15, 30, or 75 cd light output.

Compared with Xenon-type strobes, Genesis LED G1 Series appliances need fewer power supplies and often smaller wire gauge, which lightens conduit requirements. They are also backwards compatible with legacy strobes, so there's no need to replace all your existing devices to upgrade to new LED technology. In fact, G1 strobes can be mixed on the same circuit and used in the same field of view as Xenon-based strobes. This makes Genesis LED G1 Series ideal for new installations and retrofits alike.

Field-configurable sound output levels provide the flexibility modern life safety projects demand, while the Genesis LED control protocol keeps multiple strobes on compatible NAC circuits synchronized to well within NFPA 72 requirements.

Serviceability is another area where G1 Series appliances shine. The innovative under-cover diagnostic test points provide easy access to device circuit testing while mounted.

Standard Features

- **High Performance LED Strobe Technology**
 - Ultra low device current consumption
 - High efficiency optics
 - Selectable 15, 30, or 75 cd light output
 - LED devices may be mixed with legacy Xenon strobes
- **Efficient Audible Output**
 - Selectable high or low dB horn output
 - Selectable temporal or steady horn output
 - Improved audio frequency range for better wall penetration
- **Low-profile Design**
 - Compact design... single gang mounting
 - Ultra-slim... protrudes about 1" from the mounting surface
 - Attractive appearance... no visible mounting screws
- **Multiple "FIRE" Marking Options**
 - Order English, French, Spanish or no FIRE markings
 - Change markings at any time with quick-swap covers
- **Easy to Install**
 - Diagnostic test points streamline device circuit testing
 - Fits standard 1-gang electrical boxes, no trim ring needed
 - Optional trim ring available for 4-inch square boxes
 - Slide switches for field configuration
 - 12 to 18 AWG in-out screw terminals for quick wiring

Application

Strobes

Genesis LED G1 Series strobes are UL 1971-listed for use indoors as wall-mounted public-mode notification appliances for the hearing impaired. Prevailing codes require strobes to be used where ambient noise conditions exceed 105 dBA (87 dBA in Canada), where occupants use hearing protection, and in areas of public accommodation as defined in the *Americans with Disabilities Act*.

Synchronization is important in order to avoid epileptic sensitivity. All Genesis LED strobes exceed UL synchronization requirements (within 10 milliseconds over a two-hour period) when used with a synchronization source. See the specifications table for a list of compatible sources.

Horns

Genesis LED horn output reaches as high as 92 dBA and features an improved audio frequency range compared with other Genesis LED horns. This results in excellent sound penetration through walls and a clear warning of danger. They can also be set for high or low dBA output. This setting reduces horn output by about 6 dBA. Horn-only models may be ceiling-mounted or wall-mounted and may be configured for either coded or non-coded notification appliance circuits.

The suggested sound pressure level for each signaling zone used with alarm signals is at least 15 dBA above the average ambient sound level, or 5 dBA above the maximum sound level having a duration of at least 60 seconds, whichever is greater. These values are measured at five feet (1.5 m) above the floor. The average ambient sound level is A-weighted, fast response sound pressure measured over a 24-hour period.

Doubling the distance from the signal to the ear will theoretically result in a 6 dBA reduction of the received sound pressure level. The actual effect depends on the acoustic properties of materials in the space. A 3 dBA difference represents a barely noticeable change in volume.

Installation

All Genesis LED devices come with mounting screws for easy installation. The tab at the bottom of the device unlocks the cover to reveal the mounting holes. The shallow depth of Genesis LED devices leaves ample room behind them for extra wiring. Once installed with the cover in place, no mounting screws are visible.

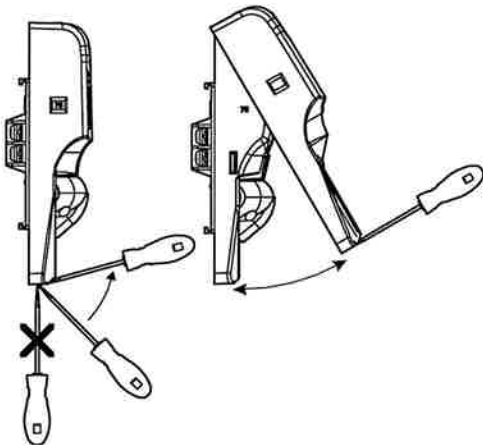

Genesis LED G1 Series horns and strobes mount to any standard one-gang surface or flush electrical box. Matching optional G1T trim rings are available to cover oversized openings and can accommodate one-gang or four-inch square boxes. Optional color matched single-gang surface boxes are also available.

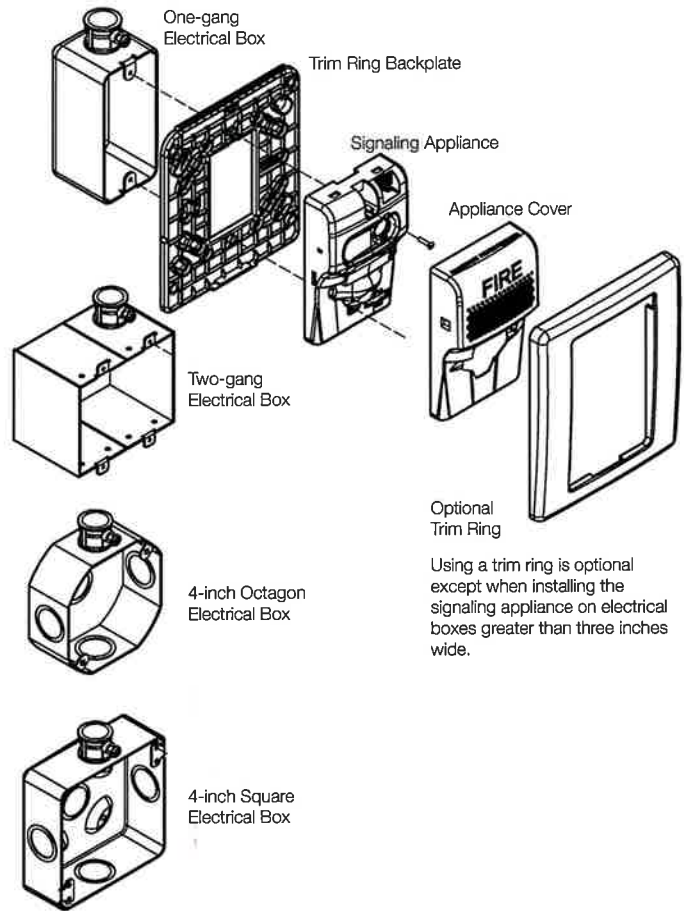

Wiring

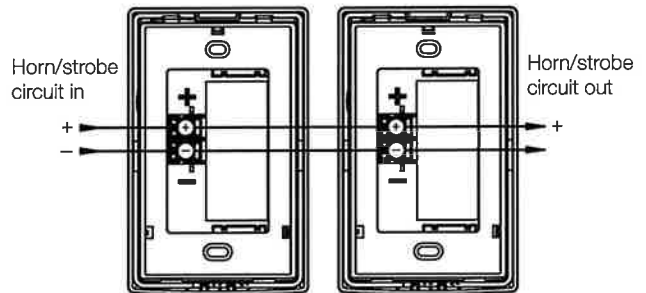

Signal polarity shown in the active condition.

Dimensions

G1 Notification Appliances

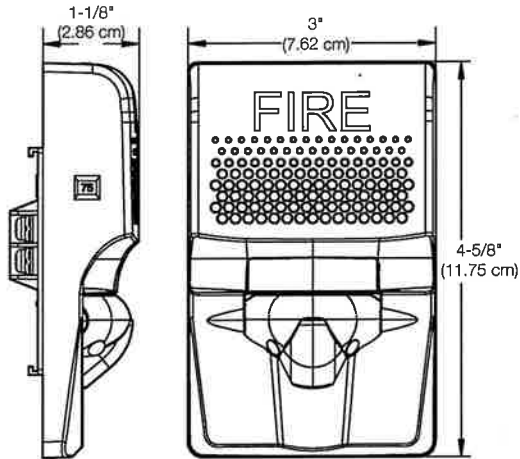

G1T Trim Ring

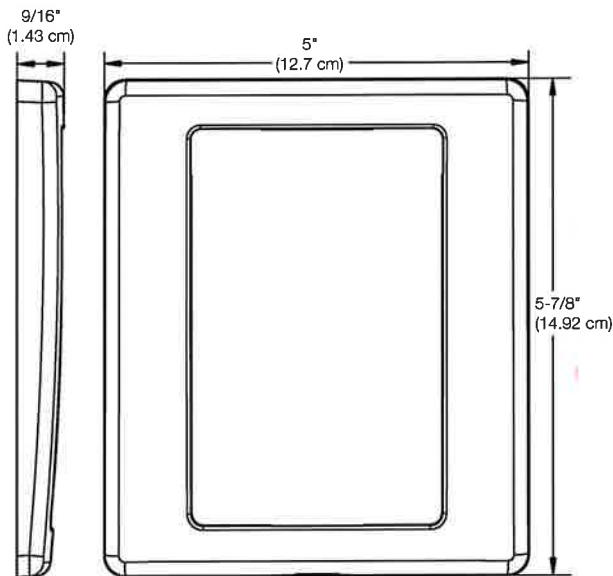

Field Configuration

Temporal horn and horn-strobe models are factory set to sound in a three-pulse temporal pattern. By sliding the tone selector switch, horn-only units may be configured for constant horn output that can be coded at precise intervals by EDWARDS control panels and control modules.

Horns and horn-strobes are factory set for high dB output. Low dB output may be selected by sliding the tone selector switch. This reduces the output by about 6 dBA.

Genesis LED clear strobes and horn-strobes may be set for 15, 30, or 75 candela output. The output setting is changed by simply removing the cover and sliding the candela switch to the desired setting. The device does not have to be removed from the wall to change the output setting. The setting remains visible through a small window on the left-hand side of the device after the cover is closed.

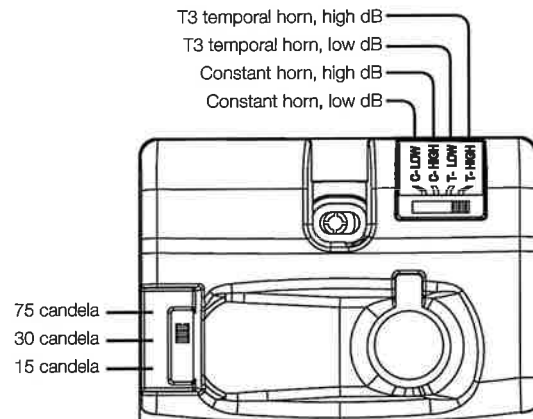

Operating current

Horns

Sound setting	16 to 33 VDC	16 to 33 VFWR
C-LOW	13 mA	15 mA
C-HIGH	23 mA	29 mA
T-LOW	13 mA	15 mA
T-HIGH	23 mA	29 mA

Strobes

Strobe setting	16 to 33 VDC	16 to 33 VFWR
15, 30, 75	24 mA	32 mA

Diagnostics

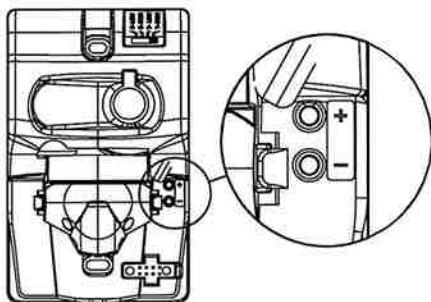

Test points indicated above are used to validate the Notification Appliance Circuit and verify device function.

Horn-Strobes

Strobe setting	Sound setting	16 to 33 VDC	16 to 33 VFWR
15, 30, 75	C-Low, T-Low	35 mA	43 mA
	C-High, T-High	45 mA	55 mA

Sound Output

Reverberant dBA (UL 464)

Sound setting	Horn	Horn-strobe
C-LOW	80	80
C-HIGH	86	86
T-LOW	80	80
T-HIGH	86	86

Anechoic dBA (CAN/ULC-S525)

Sound setting	Horn	Horn-strobe
C-LOW	86	86
C-HIGH	92	92
T-LOW	86	86
T-HIGH	92	92

Sound pattern (ULC)

Axis	Angle	Change in output
Horizontal	45° and 115°	-3 dBA
	5° and 130°	-6 dBA
Vertical	65° and 135°	-3 dBA
	45° and 140°	-6 dBA

Light Distribution

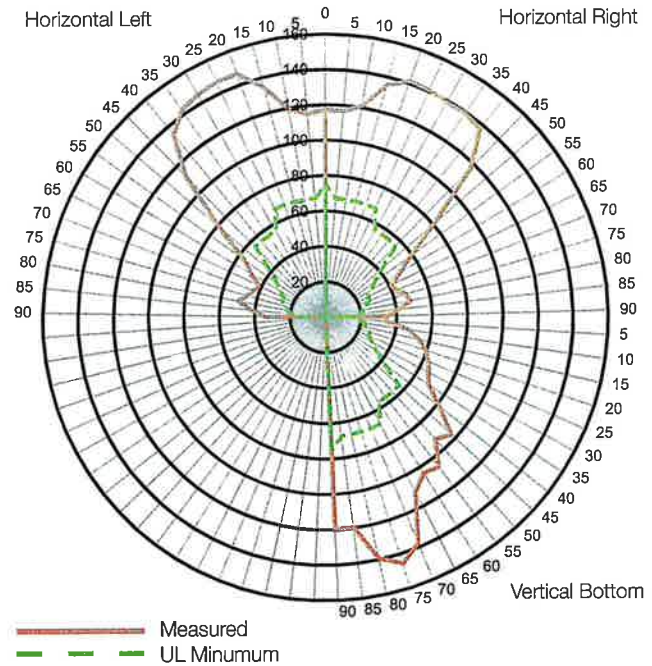



Specifications

Operating voltage	16 to 33 VDC, 16 to 33 VFWR
Horn signal type	Constant or T3 temporal
Light output	15, 30, or 75 candela
Strobe flash rate	1 fps (flash per second) approx.
Synchronization	20 Ω max. between any two devices. (To determine allowed wire resistance, refer to these specifications, and the specifications for the synchronized signal source.)
Synchronization sources	EDWARDS CC Series Signal Modules, Booster and Auxiliary Power Supplies, and Intelligent and Conventional Control Panels
Wire size	12 to 18 AWG (0.75 to 2.50 mm ²)
Dimensions (WxHxD)	3 x 4-5/8 x 1-1/8 in. (7.62 x 11.75 x 2.86 cm)
Strobe-to-box center offset	-0.71 inches (-1.8 cm)
Compatible electrical boxes [1]	1-gang, 2-gang, 4-inch octagon, 4-inch square
Trim rings	G1TR, G1TW - Dimensions 5 x 5-7 x 9/16 in. (12.7 x 14.92 x 1.43 cm)
Agency Listings	FCC, ICC, UL1971, UL1638, UL464, CSFM (All models comply with ADA code of federal regulation Chapter 28 Part 36 final rule)
Operating environment	
Temperature	32 to 122°F (0 to 50°C)
Relative humidity	0 to 93% noncondensing

[1] Electrical boxes must be at least 1-1/2 in. (3.81 cm) deep. Electrical boxes greater than three inches wide require a trim ring.

Ordering Information

Notification Appliances		Color	Marking
 Horns Selectable High/low dB	G1ARF	Red	FIRE
	G1ARF-FR	Red	FEU
	G1ARF-SP	Red	FUEGO
	G1ARN	Red	None
	G1AWF	White	FIRE
	G1AWF-FR	White	FEU
	G1AWF-SP	White	FUEGO
	G1AWN	White	None

 Strobes Selectable 15, 30, 75 cd	G1VRF	Red	FIRE
	G1VRF-FR	Red	FEU
	G1VRF-SP	Red	FUEGO
	G1VRN	Red	None
	G1VWA*	White	ALERT
	G1VWF	White	FIRE
	G1VWF-FR	White	FEU
	G1VWF-SP	White	FUEGO
	G1VWN	White	None

 Horn-strobes Selectable 15, 30, 75 cd, High/low dB	G1AVRF	Red	FIRE
	G1AVRF-FR	Red	FEU
	G1AVRF-SP	Red	FUEGO
	G1AVRN	Red	None
	G1AWF	White	FIRE
	G1AWF-FR	White	FEU
	G1AWF-SP	White	FUEGO
	G1AWN	White	None

Replacement Appliance Covers		Color	Marking
 Horn Covers	G1ARA-CVR	Red	ALERT
	G1ARF-CVR	Red	FIRE
	G1ARF-FR-CVR	Red	FEU
	G1ARF-SP-CVR	Red	FUEGO
	G1ARN-CVR	Red	None
	G1AWA-CVR	White	ALERT
	G1AWF-CVR	White	FIRE
	G1AWF-FR-CVR	White	FEU
	G1AWF-SP-CVR	White	FUEGO
G1AWN-CVR	White	None	

 Strobe Covers	G1VRA-CVR	Red	ALERT
	G1VRF-CVR	Red	FIRE
	G1VRF-FR-CVR	Red	FEU
	G1VRF-SP-CVR	Red	FUEGO
	G1VRN-CVR	Red	None
	G1VWA-CVR	White	ALERT
	G1VWF-CVR	White	FIRE
	G1VWF-FR-CVR	White	FEU
	G1VWF-SP-CVR	White	FUEGO
G1VWN-CVR	White	None	

 Horn-strobe Covers	G1AVRA-CVR	Red	ALERT
	G1AVRF-CVR	Red	FIRE
	G1AVRF-FR-CVR	Red	FEU
	G1AVRF-SP-CVR	Red	FUEGO
	G1AVRN-CVR	Red	None
	G1AWA-CVR	White	ALERT
	G1AWF-CVR	White	FIRE
	G1AWF-FR-CVR	White	FEU
	G1AWF-SP-CVR	White	FUEGO
G1AWN-CVR	White	None	

Accessories

	G1TR	Trim ring, G1 Series, red		G1TW	Trim ring, G1 Series, white
27193-11	One-gang surface mount box, red	27193-16	One-gang surface mount box, white		

Model Number Syntax, Appliances

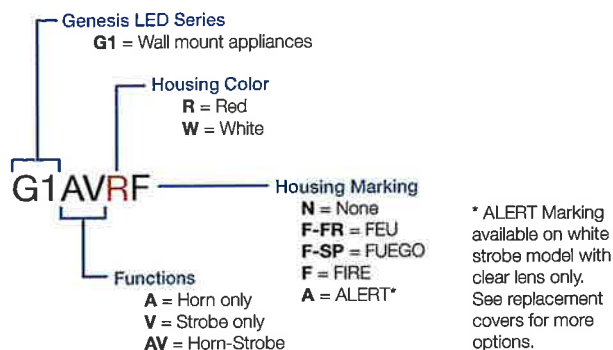

Model Number Syntax, Replacement Covers

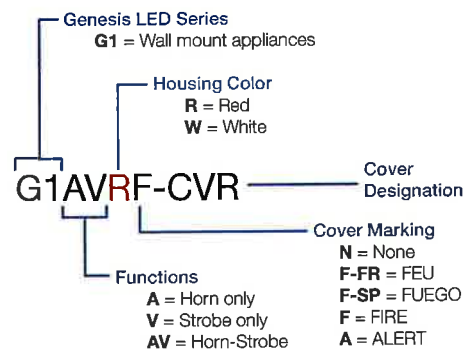



LIFE SAFETY & INCIDENT MANAGEMENT

Contact us...

Email: edwards.fire@fs.utc.com
Web: edwards-fire.com

1016 Corporate Park Drive
Mebane, NC 27302

EDWARDS is a registered mark in the
United States and other countries.

© 2018 United Technologies Corporation.
All rights reserved.

Technology that saves lives

Synchronization Output Module

GSA-CC1S, MCC1S

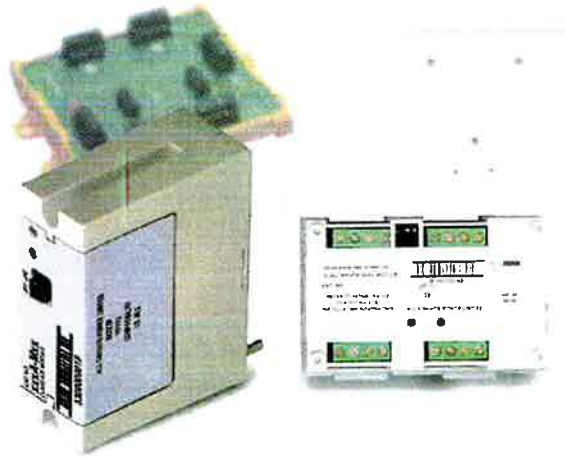

Overview

GSA-CC1S and MCC1S Synchronization Output Modules are intelligent analog addressable devices that form part of Kidde's Signature line of products. The actual operation of the GSA-CC1S and MCC1S is determined by the "personality code" selected by the installer, which is downloaded to the module from the Signature loop controller during system configuration.

Depending on their assigned personality, Synchronization Output Modules may be used as a signal power riser selector to provide synchronization of fire alarm signals across multiple zones, or for connecting, upon command from the loop controller, supervised Class B signal or telephone circuits to their respective power inputs. The power inputs may be polarized 24 Vdc to operate audible and visible signal appliances or 25 and 70 VRMS to operate audio evacuation speakers and firefighter's telephones.

Standard Features

- Provides UL 1971-compliant auto-sync output for visual signals**
 Use for connecting a supervised output circuit to a supervised 24 Vdc riser input and synchronizing multiple notification appliance circuits.
- Functions as an audible signal riser selector**
 Use as a synch module or for connecting supervised 24 Vdc Audible/Visible signal circuits, or 25 and 70 VRMS Audio Evacuation and Telephone circuits to their power inputs.
- Built-in ring-tone generator**
 When configured for telephone circuits, the GSA-CC1S generates its own ring-tone signal, eliminating the need for a separate ring-tone circuit.
- Automatic device mapping**
 Signature modules transmit information to the loop controller regarding their circuit locations with respect to other Signature devices on the wire loop.
- Electronic addressing**
 Programmable addresses are downloaded from the loop controller, a PC, or the SIGA-PRO Signature Program/Service Tool; there are no switches or dials to set.
- Intelligent device with microprocessor**
 All decisions are made at the module to allow lower communication speed with substantially improved control panel response time and less sensitivity to line noise and loop wiring properties; twisted or shielded wire is not required.

Application

The **GSA-CC1S** mounts to a standard North American two-gang electrical box, making it ideal for locations where only one module is required. Separate I/O and data loop connections are made to each module.

The **GSA-MCC1S** is part of the UIO family of plug-in Signature Series modules. It functions identically to the GSA-CC1S, but takes advantage of the modular flexibility and easy installation that characterize all UIO modules. Two- and six-module UIO motherboards are available. These can accommodate individual risers for each on-board module, or risers that are shared by any combination of its UIO modules. All wiring connections are made to terminal blocks on the motherboard. UIO assemblies may be mounted in Kidde enclosures.

Personality Codes

The operation of the GSA-CC1S is determined by their sub-type code or "Personality Code". The code is selected by the installer depending upon the desired application and is downloaded from the loop controller.

Personality Code 5: Signal Power or Audio Evacuation (single riser). Configures the module for use as a Class B Audible/Visible Signal power (24 Vdc polarized) or Audio Evacuation (25 or 70 VRMS) power selector. The ring-tone generator is disabled. The output circuit is monitored for open or shorted wiring. If a short exists, the control panel inhibits the activation of the audible/visible signal circuit to prevent connection to the power circuit.

Personality Code 6: Telephone with ring-tone (single riser). Configures the module for use as a Telephone power selector. When a telephone handset is plugged into its jack or lifted from its hook, the module generates its own Ring-Tone signal. A separate ring-tone circuit is not needed. The module sends this signal to the control panel to indicate that an off-hook condition is present. When the system operator responds to the call, the ring-tone signal is disabled.

Personality Code 25: Visual Signal Synchronization. This personality code configures the module to provide synchronization of fire alarm signals across multiple zones. It functions as a signal power (24 Vdc) riser selector. The output wiring is monitored for open circuits and short circuits. A short circuit will cause the fire alarm control panel to inhibit the activation of the audible/visual signal circuit so the riser is not connected to the wiring fault.

Warnings & Cautions

This module will not operate without electrical power. As fires frequently cause power interruption, we suggest you discuss further safeguards with your fire protection specialist.

Kidde recommends that these modules be installed according to latest recognized edition of national and local fire alarm codes.

Compatibility

These modules are part of Kidde's Signature Series intelligent processing and control platform. They are compatible with VM, and VS Series control panels.

Installation

The **GSA-CC1S**: mounts to North American 2-1/2 inch (64 mm) deep 2-gang boxes and 1-1/2 inch (38 mm) deep 4 inch square boxes with 2-gang covers and GSA-MP mounting plates. The terminals are suited for #12 to #18 AWG (2.5 mm² to 0.75 mm²) wire size.

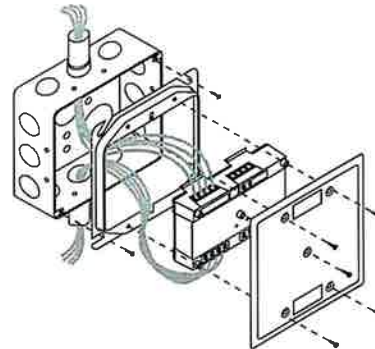

GSA-MCC1S: mount the UIOxR motherboard inside a suitable Kidde enclosure with screws and washers provided. Plug the module into any available position on the motherboard and secure the module to the motherboard with the captive screws. Wiring connections are made to the terminals on the motherboard (see wiring diagram). UIOxR motherboard terminals are suited for #12 to #18 AWG (2.5 mm² to 0.75 mm²) wire size.

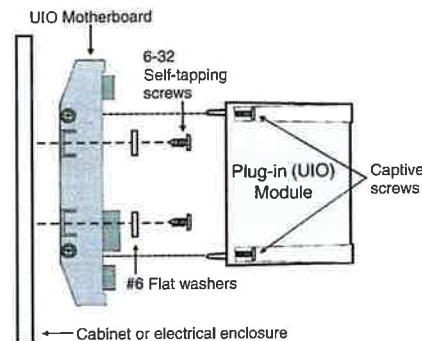

Electronic Addressing

The loop controller electronically addresses each module saving valuable time during system commissioning. Setting complicated switches or dials is not required. Each module has its own unique serial number stored in its "on-board memory". The loop controller identifies each device on the loop and assigns a "soft" address to each serial number. If desired, the modules can be addressed using the SIGA-PRO Signature Program/Service Tool.

Testing & Maintenance

The module's automatic self-diagnosis identifies when it is defective and causes a trouble message. The user-friendly maintenance program shows the current state of each module and other pertinent messages. Single modules may be turned off (de-activated) temporarily, from the control panel.

Scheduled maintenance (Regular or Selected) for proper system operation should be planned to meet the requirements of the Authority Having Jurisdiction (AHJ). Refer to current NFPA 72 and ULC CAN/ULC 536 standards.

Typical Wiring

GSA-CC1S (Standard Mount)

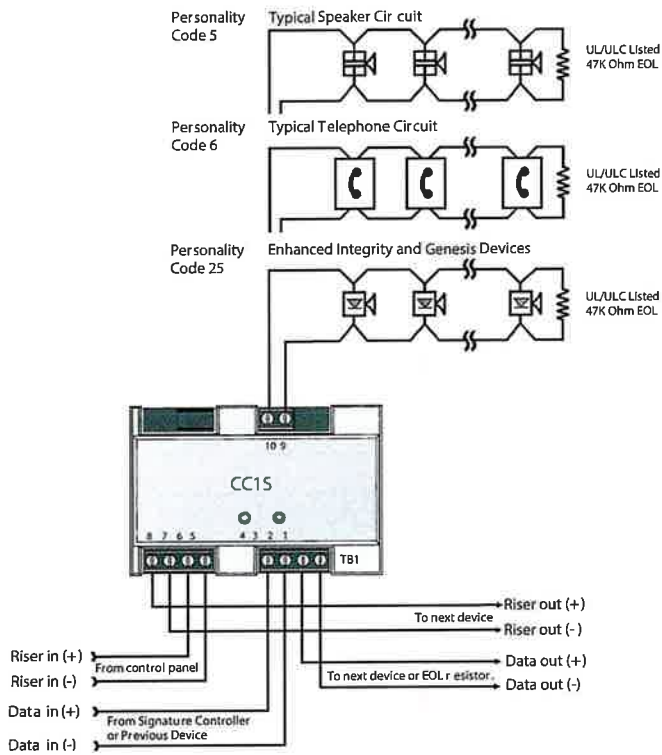

GSA-MCC1S (UIO Mount)

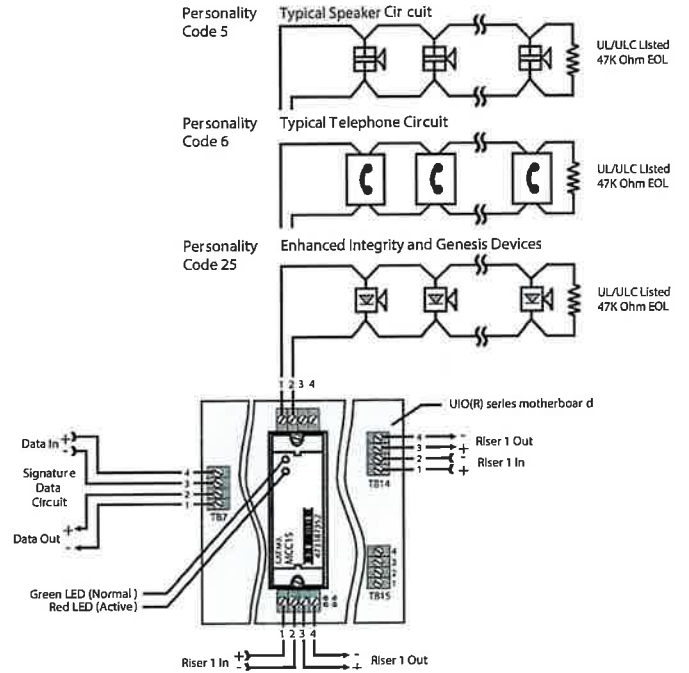

Multiple CC1(S) modules using the MIBRBS's sense inputs

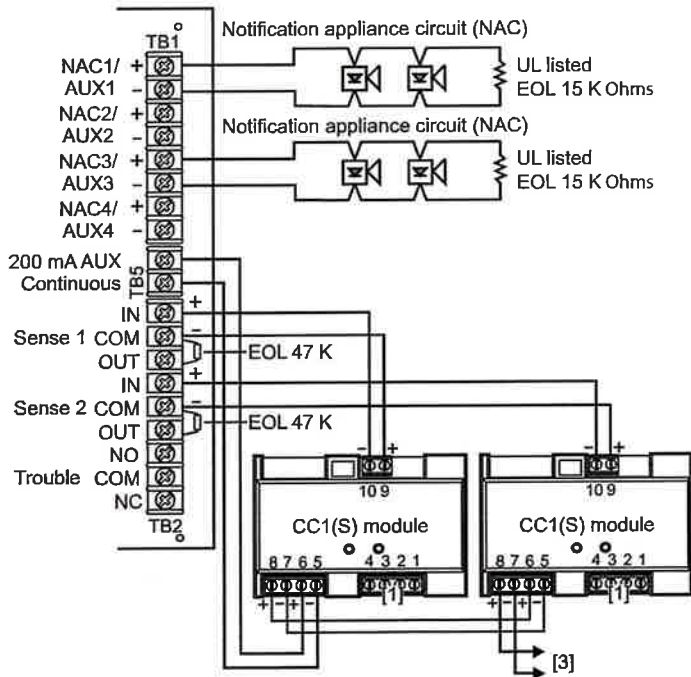



Technology that saves lives

Contact us...

Email: kidde.fire@fs.utc.com
 Web: kidde.com/engineeredsystems

1016 Corporate Park Drive
 Mebane, NC 27302

Kidde is a registered mark in the United States and other countries.

© 2018 Walter Kidde Portable Equipment. All rights reserved.

Specifications

Catalog Number	GSA-CC1S	GSA-MCC1S
Mounting	North American 2½ inch (64 mm) deep two-gang boxes and 1½ inch (38 mm) deep 4 inch square boxes with 2-gang covers and GSA-MP mounting plates	Plugs into UIO2R, UIO6R or UIO6 Motherboards
Description	Synchronization Output Module	
Type Code	50 (factory set)	
Address Requirements	Uses one module address	
Wiring Terminations	Suitable for #12 to #18 AWG (2.5 mm ² to 0.75mm ²)	
Operating Current	Standby = 223µA Activated = 100µA	
Operating Voltage	15.2 to 19.95 Vdc (19 Vdc nominal)	
Output Rating	24 Vdc = 2 amps 25 V Audio = 50 watts 70 V Audio = 35 watts	
Construction	High Impact Engineering Polymer	
Storage and Operating Environment	Operating: 32°F to 120°F (0°C to 49°C) Storage: -4°F to 140°F (-20°C to 60°C) Humidity: 0 to 93% RH	
LED Operation	Green LED - Flashes when polled Red LED - Flashes when in alarm/active	
Compatibility	Use with: Signature Loop Controller	
Agency Listings	UL, ULC, CSFM, MEA	

Ordering Information

Catalog Number	Description	Shipping Wt. lbs (kg)
GSA-CC1S	Synchronization Output Module (Standard Mount) - UL/ULC Listed	0.5 (0.23)
GSA-MCC1S	Synchronization Output Module (UIO Mount) - UL/ULC Listed	0.18 (0.08)

Related Equipment

27193-21	Surface Mount Box - Red, 2-gang	2 (1.2)
27193-26	Surface Mount Box - White, 2-gang	2 (1.2)
GSA-UIO2R	Universal Input-Output Module Board w/Riser Inputs - Two Module Positions	0.32 (0.15)
GSA-UIO6R	Universal Input-Output Module Board w/Riser Inputs - Six Module Positions	0.62 (0.28)
GSA-UIO6	Universal Input-Output Module Board - Six Module Positions	0.56 (0.25)
235196P	Bi-polar Transient Protector	0.01 (0.05)
MFC-A	Multifunction Fire Cabinet - Red, supports Signature Module Mounting Plates	7.0 (3.1)
GSA-MP1	Signature Module Mounting Plate, 1 footprint	1.5 (0.70)
GSA-MP2	Signature Module Mounting Plate, 1/2 footprint	0.5 (0.23)
GSA-MP2L	Signature Module Mounting Plate, 1/2 extended footprint	1.02 (0.46)



Southwire®

FPLR - FIRE ALARM CABLE STANDARD -- Riser Rated – Bare Copper – PVC



APPLICATIONS

Fire protective signaling circuits. Also for smoke detectors, voice communications, audio control and initiating circuits. Article 760 of the NEC.

CONSTRUCTION

- A.) CONDUCTOR
- B.) INSULATION
- C.) COLOR CODE
- D.) ASSEMBLY
- E.) JACKET

Solid Bare Copper or Stranded Bare Copper

PVC

Black, Red, Green, Yellow. (4C 18AWG Stranded is Black, Red, White, Green)

Cabled with ripcord, and jacketed.

PVC

COMPLIANCE

- A.) SPECIFICATION
- B.) CABLE TYPE
- C.) FLAME TEST
- D.) VOLTAGE
- E.) TEMPERATURE
- F.) SUITABLE USE:
- G.) QA

UL 1424

FPLR (NEC / UL)

UL 1666; FT4

300V

75C

Fire protective signaling circuits, smoke detectors, audio, control, and initiating circuits.

(UL) Listed / (UL) FPLR

FEATURES & OPTIONS:

Available in 1000 ft or 500 ft packages, reels, RIBs, or pull-boxes where practicable.

Optional: other colors, jackets with extruded stripes, and composite cables for multiple services, jacketed, or armored as permitted.

Solid BC

Stock Code	DESCRIPTION	Cable Type	AWG	#/C	STR/ SOL	BC/ TD	SHIELD	UL/NEC
F40021	18/2C SOL BC N/S FPLR	FPLR	18	2	SOL	BC	N/S	FPLR
F40568	18/4C SOL BC N/S FPLR		18	4				
F50004	16/2C SOL BC N/S FPLR		16	2				
F50383	16/4C SOL BC N/S FPLR		16	4				
F60001	14/2C SOL BC N/S FPLR		14	2				
F60355	14/4C SOL BC N/S FPLR		14	4				
F70004	12/2C SOL BC N/S FPLR		12	2				
F40015	18/2C SOL BC SHLD FPLR	FPLR	18	2	SOL	BC	SHLD	FPLR
F40567	18/4C SOL BC SHLD FPLR		18	4				
F50010	16/2C SOL BC SHLD FPLR		16	2				
F50382	16/4C SOL BC SHLD FPLR		16	4				
F60030	14/2C SOL BC SHLD FPLR		14	2				
F60354	14/4C SOL BC SHLD FPLR		14	4				
F70015	12/2C SOL BC SHLD FPLR		12	2				

Stranded BC

Stock Code	DESCRIPTION	Cable Type	AWG	#/C	STR/ SOL	BC/ TD	SHIELD	UL/NEC
F40142	18/2C STR BC N/S FPLR	FPLR	18	2	STR	BC	N/S	FPLR
F50289	16/2C STR BC N/S FPLR		16	2				
F60340	14/2C STR BC N/S FPLR		14	2				
F70092	12/2C STR BC N/S FPLR		12	2				
F40370	18/2C STR BC SHLD FPLR	FPLR	18	2	STR	BC	SHLD	FPLR
F40150	18/4C STR BC SHLD FPLR		18	4				
F50375	16/2C STR BC SHLD FPLR		16	2				
F60341	14/2C STR BC SHLD FPLR		14	2				

*Products are subject to 25,000' minimum orders. Call your Southwire representative for further details.

Edwards Signaling

R-Series Remote Annunciators

E-RLCD, E-RLCD-C, E-RLED-C,
RLED24, GCI

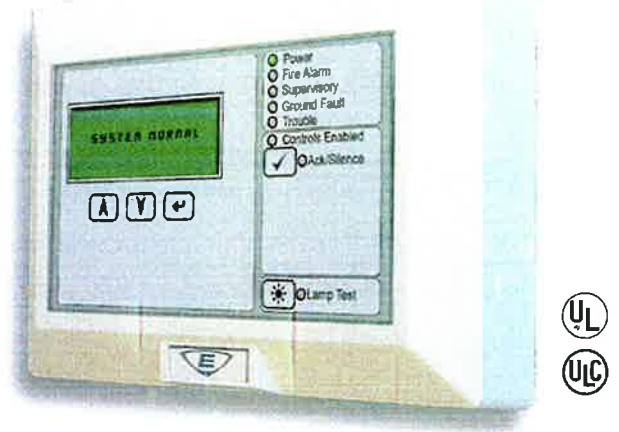

Overview

Edwards R-Series Annunciators are high-performance remote annunciators that provide status indication and common controls for compatible fire alarm control panels, including E-FSA-Series small analog fire alarm systems. This family of annunciators offers LCD or LED annunciation. Models are available with and without common controls.

There are three R-Series annunciator models, plus an LED-based expander. Up to two expanders can be connected to any annunciator. The expander includes 24 pairs of LEDs that extend the capabilities of any of the annunciators.

All annunciator models include status LEDs and an internal buzzer. Two models have an LCD text display, and one has 16 pairs of LEDs for zone annunciation. LCD models feature a large back-lit, four by twenty character per line, super-twist liquid crystal display.

R-Series annunciators and expanders are mounted on a standard 4-inch square electrical box, using the included mounting ring. They can also be surface mounted in locking steel enclosures. Three different enclosures are available.

A keyswitch and graphic annunciator interface is available for R-Series annunciator applications. The keyswitch enables or disables common controls. The graphic annunciator interface cards supports 32 LEDs and 16 switches on the graphic panel display.

Features

- LCD models feature large 4 x 20 character backlit LCD display
- LED models provide 16 pairs of LEDs for zone annunciation
- Available expander extends capability with 24 pairs of LEDs
- Up to two expanders may be wired to each annunciator
- Status LEDs and internal buzzer standard on all models
- Common controls available for LED and LCD display models
- Available keyswitch for disabling common controls
- Standard 4-inch square electrical box mounting
- Class B or Class A RS485 wiring standard
- One-, two-, and three-position enclosures available
- Graphic Annunciator interface, includes common control, indicators and 32 LEDs
- No programming required, set the address and unit receives all information from panel

Application

R-Series annunciators communicate with the FACP on the RS-485 data riser. This can be configured for Class A or Class B communication. Annunciators do not provide ground fault isolation.

These annunciators are stand-alone units that can be powered by the FACP or by an approved power supply.

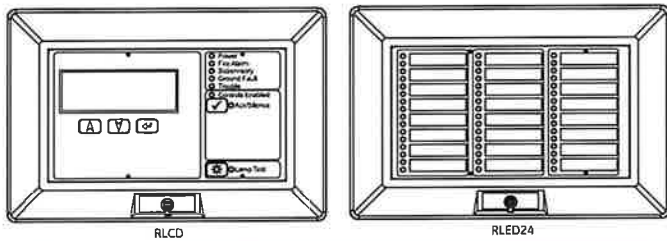
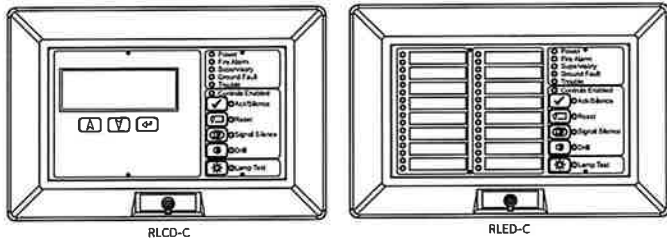

Features by model

	E-RLCD	E-RLCD-C	E-RLED-C	RLED24
Reset	✓	✓	✓	-
Ack/Silence	✓	✓	✓	-
Fire Alarm	✓	✓	✓	-
Supervisory	✓	✓	✓	-
Ground Fault	✓	✓	✓	-
Trouble	✓	✓	✓	-
Controls Enabled	✓	✓	✓	-
Ack/Silence	✓	✓	✓	-
Reset	✓	✓	✓	-
Signal Silence	✓	✓	✓	-
Drill	✓	✓	✓	-
Lamp Test	✓	✓	✓	-
LCD Display	✓	✓	✓	-
Zone Active LEDs	-	-	16 *	24 **
Zone Trouble LEDs	-	-	16	24

* zones 13-16 may be selected as Supervisory on E-FSA64

** zones 13-16 and 29-32 may be selected as Supervisory on E-FSA250

Graphic Annunciator Interface

The GCI Graphic Annunciator Driver is an interface card that connects the fire alarm control panel to the display panel of an LED-based graphic annunciator.

The annunciator card supports 32 LEDs and 16 switches on the graphic panel display. It includes status LEDs and an internal buzzer.

The graphic interface is supplied with snap track mounting. It is attached to a plastic mounting rail that requires two EIA panels.

The annunciator communicates with the FACP on the RS-485 data riser. This can be configured for Class A or Class B communication. The annunciator does not provide ground fault isolation. It is a stand-alone unit that can be powered by the FACP or by an approved power supply.

Graphic Annunciator Interface Specifications

Alarm current	146 mA at 24 Vdc (with 36 LEDs ON)
Standby current	36 mA at 24 Vdc (with no LEDs ON)
Maximum current	10 mA per LED

Annunciator Wiring

Annunciator, Class A

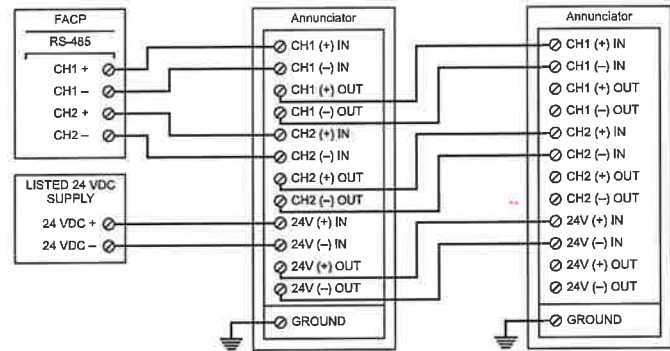

Annunciator, Class B

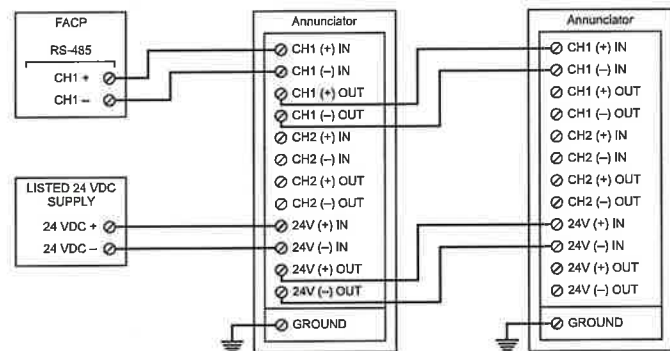

Expander

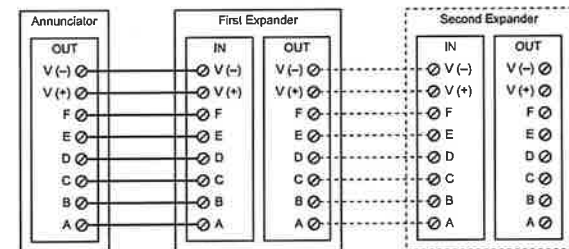

Remote Keyswitch

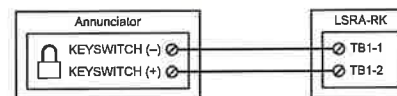

Keyswitch Specifications

Maximum voltage	5 Vdc
Maximum current	200 mA
Mounting	2-1/2 in (64 mm) deep 1-gang box
Termination	Screw terminals
Maximum wire size	12 AWG (2.5 mm sq)
Contact configuration	Normally open

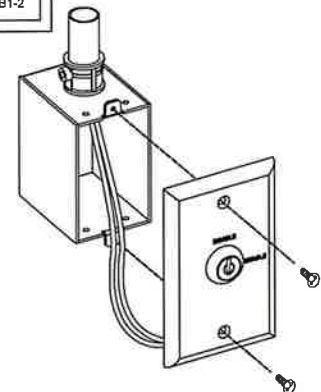

Annunciator Connections

Annunciator

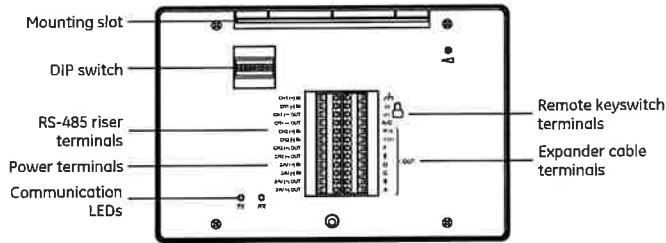

Expander

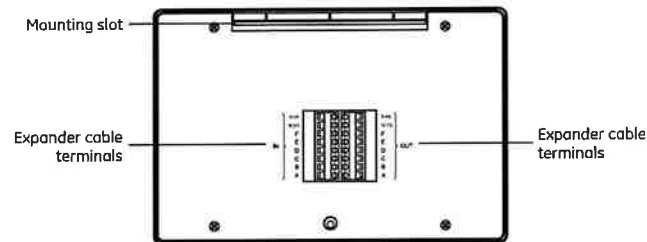

DIP switch settings

Switch	Description and values
S1 to S5	The annunciator network address (in binary).
Network address	The factory setting is for address 2. Examples: 10000 = 1 01000 = 2 11000 = 3 00100 = 4
S6 Network baud rate	OFF = 9600 baud (factory default setting) ON = 38,400 baud
S7 to S8	Not used

Annunciator Mounting

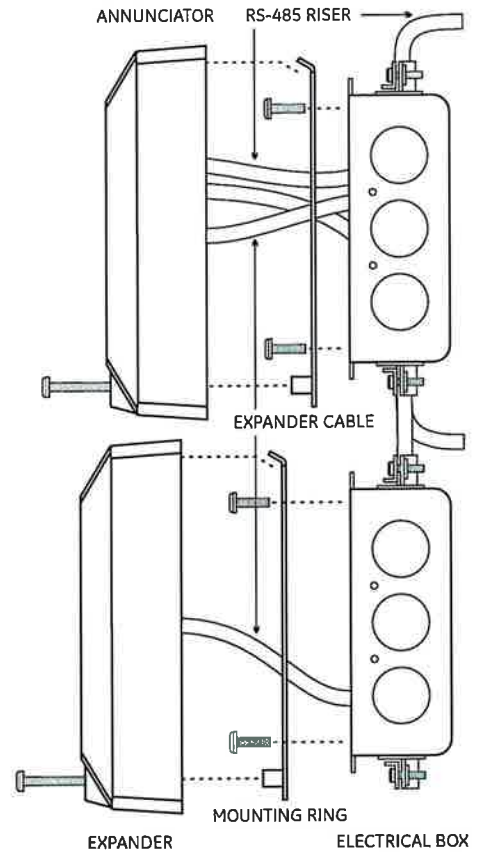

Annunciator Enclosures

The RA Remote Annunciator Enclosures provide secure, surface mounted protection for annunciators and extenders. Each consists of a back plate, hinged cover, and key lock.

The enclosures are 16-gauge welded steel with a white, painted finish. Each enclosure includes a security lock and two keys. The two- and three-position enclosures have wiring channels for correct routing of interconnections.

The enclosures attach to a standard electrical box, and provide a mounting lip that takes the place of the integral mounting ring supplied with the annunciators and expanders.

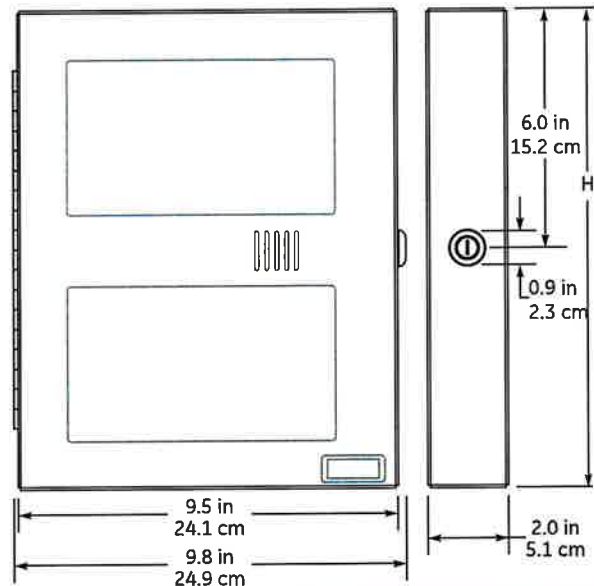
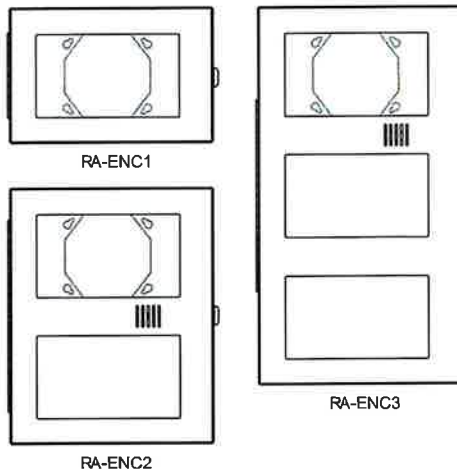

Dimensions (H x W x D)

RA-ENC1	6.3 x 9.8 x 2.0 in (16.0 x 24.9 x 5.1 cm)
RA-ENC2	12.0 x 9.8 x 2.0 in (30.5 x 24.9 x 5.1 cm)
RA-ENC3	17.7 x 9.8 x 2.0 in (45.0 x 24.9 x 5.1 cm)

Note: Allow approximately 2 inches (50 cm) clearance on both sides of the enclosure, to permit inserting and removing the key, and opening the door through 90 degrees.



Contact us...

Phone: 1-800-336-4206

Web: www.edwardssignaling.com

Edwards Signaling is an **EDWARDS** brand.

3 Farm Glen Boulevard
Farmington, CT 06032

In Canada, contact Chubb Edwards...

Email: inquiries@chubbedwards.com

Web: www.chubbedwards.com

© 2013 UTC Fire & Security Americas Corporation, Inc. All rights reserved. Specifications subject to change without notice. Edwards is part of UTC Climate, Controls & Security, a unit of United Technologies Corporation.

Specifications

	E-RLCD-C	E-RLCD	E-RLED-C	RLED24
Operating voltage	24 VDC, continuous.			
Standby current	99 mA	98 mA	28 mA	6 mA
Alarm current	115 mA	113 mA	62 mA	34 mA
RS-485 communications	Class A or Class B, 9600 baud			
Data wiring	18 to 14 AWG (1.0 to 2.5 sq mm) twisted pair (6 twists per foot minimum). Maximum wire run is 4,000 ft. (1,219 m)			
Remote key switch circuit	5 VDC at 1 mA, power-limited, unsupervised			
Ground fault impedance	0			
Power wiring	18 to 14 AWG (1.0 to 2.5 sq. mm)			
Display area	4 lines of 20 characters each			
Dimensions (H x W x D)	5-5/8 x 8-1/2 x 1-1/2 in. (14.3 x 21.4 x 3.8 cm)			
Mounting	North American 4-inch square electrical box or listed enclosure			
Agency Listing	UL, ULC			
Operating environment	Temperature: 32 to 120°F (0 to 49°C) Humidity: 0 to 93% RH, noncondensing at 90°F (32°C)			

Ordering Information

Part	Description
Remote Annunciators	
E-RLCD	LCD text annunciator without common controls. English.
E-RLCD-C	LCD text annunciator with common controls. English.
E-RLED-C	16-pair LED zone annunciator with common controls. English.
Remote Expanders	
RLED24	24-pair LED zone expander with expander cable and zone card insert.
Enclosures	
RA-ENC1	One-position enclosure for Remote Annunciator.
RA-ENC2	Two-position enclosure for Remote Annunciator and one Remote Expander, including one interconnection cable.
RA-ENC3	Three-position enclosure for Remote Annunciator and two Remote Expanders, including two interconnection cables.
LSRA-SB	Surface Mount Box - for single R Series annunciator.
Graphic Annunciator Drivers	
GCI	Graphic Annunciator Driver, provides outputs for common indicators and 32 alarm/supv zones as well as inputs for common switches. Provided with a snap track for mounting in custom graphic enclosures.
Accessories	
RKEY	Remote key switch on plate for enabling or disabling common controls (Lock/Unlock).
27193-16	Electrical box, surface mount, white, single-gang, for RKEY.

Sealed Lead-Acid Batteries



Overview

Rechargeable sealed lead-acid batteries are ideal for use as a secondary (standby) power source as defined by NFPA 72. Their low maintenance and high energy density make them ideal for fire alarm signaling applications.

Standard Features

- Rechargeable
- Non-spillable
- Non-hazardous
- Low maintenance
- High energy density

Application

When multiple power supplies are provided, each power supply's battery requirements should be calculated individually. Consult the specific system manual to determine battery capacity requirements.

Safety Information

Due to a battery's low internal resistance and high power density, high levels of short circuit current can develop across battery terminals. Put on protective eye covering and remove all jewelry before working on batteries. Do not rest tools or cables on the battery, and only use insulated tools. Follow all manufacturers installation instructions and diagrams when installing or maintaining batteries.



Contact us...

Email: edwards.fire@fs.utc.com

Web: www.est-fire.com

EST is an **EDWARDS** brand.

1016 Corporate Park Drive
Mebane, NC 27302

In Canada, contact Chubb Edwards...

Email: inquiries@chubbedwards.com

Web: www.chubbedwards.com

© 2013 UTC Fire & Security Americas Corporation, Inc. All rights reserved. Specifications subject to change without notice. Edwards is part of UTC Climate, Controls & Security, a unit of United Technologies Corporation.

Specifications

Case Material	ABS Thermoplastic
Regulatory Information	DOT Class 60, Batteries, non-hazardous, non-spillable
Operating Environment	32° F to 120° F (0° C to 49° C) 0 to 93% RH, Non-condensing

Ordering Information

Catalog Number	Description	Shipping Weight, lb (kg)
12V1A2	1.2 Ah Sealed Lead Acid Battery - 12 Vdc	1.25 (0.57)
12V4A	4.5 Ah Sealed Lead Acid Battery - 12 Vdc	5 (2.27)
12V6A5	7.2 Ah Sealed Lead Acid Battery - 12 Vdc	6 (2.72)
6V8A	8 Ah Sealed Lead Acid Battery - 6 Vdc	4 (1.81)
6V10A	12 Ah Sealed Lead Acid Battery - 6 Vdc	5 (2.27)
12V10A	11 Ah Sealed Lead Acid Battery - 12 Vdc	10 (4.45)
12V17A	18 Ah Sealed Lead Acid Battery - 12 Vdc	13 (5.90)
12V24A	26 Ah Sealed Lead Acid Battery - 12 Vdc	20 (9.07)
12V40A	40 Ah Sealed Lead Acid Battery - 12 Vdc	32 (14.51)
12V50A	50 Ah Sealed Lead Acid Battery - 12 Vdc	40 (18.14)
12V65A	65 Ah Sealed Lead Acid Battery - 12 Vdc	49 (22.23)

VS4-R

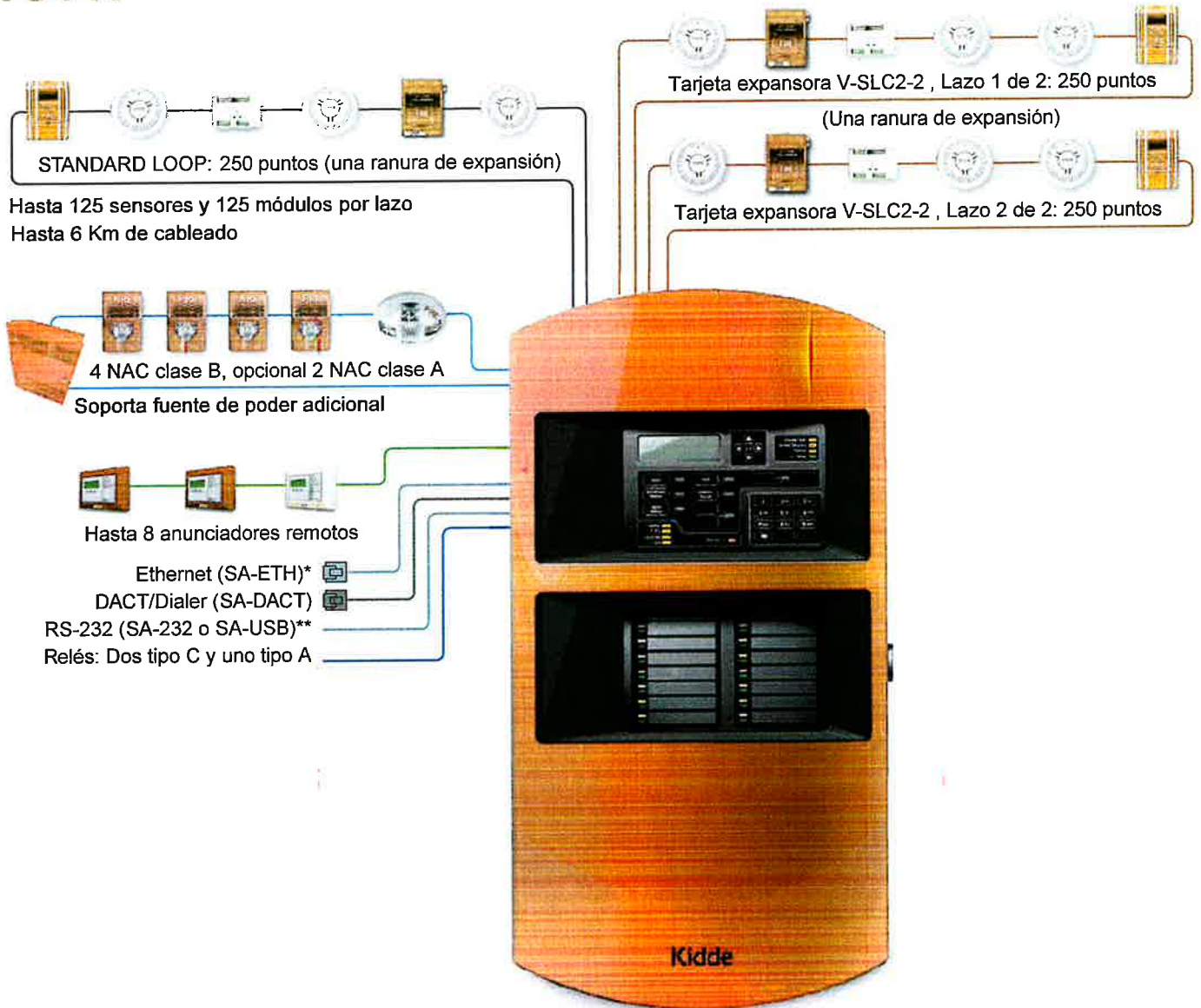

Panel de alarma para detección de incendio, soporta un lazo Clase B o Clase A de hasta 250 dispositivos.

- Cada lazo permite la combinación de 125 sensores y 125 módulos.
- Soporta la expansión de 4 lazos dando capacidad de hasta 1000 dispositivos
- Incorpora 4 NAC clase B de 6A en total, 2.5A máx por NAC.
- Configurable por software.
- Soporta Mapeo inteligente de dispositivos.



Tarjetas expansoras de lazo

V-SLC2-1



Tarjeta de expansión de 1 lazo para panel de alarma VS4 y VS1

- Otorga 1 lazo Clase B o Clase A
- La tarjeta permite agregar 250 dispositivos adicionales al VS4 y 64 dispositivos al VS1

V-SLC2-2



Tarjeta de expansión de 2 lazos para panel de alarma VS4

- Otorga 2 lazos Clase B o Clase A
- Cada lazo tiene capacidad de 125 detectores y 125 módulos
- La tarjeta permite agregar 500 dispositivos adicionales