



No. de cotización: **MONT-CF-2020-016**

31 de marzo

Señores:

Junta Central Electoral

Santo Domingo

Atención:

Comité de compras y contrataciones

Distinguidos Señores:

Atendiendo a su solicitud, presentamos nuestra propuesta para la adquisición de montacargas de combustión GLP con las **siguientes características:**

Especificaciones Técnicas

Configuración:

- Mástil triple con altura máxima de 188 Pulgadas (4.8 M)
- Altura con torre recogida 93 Pulgadas (2.3 M)
- Tres (3) válvulas auxiliares para 3 funciones hidráulicas
- Movimiento lateral de horquilla (SIDE SHIFTER)
- Respaldo de carga
- Uñas de 48 pulgadas de longitud
- Gomas macizas
- Carriage

Luces y Alarmas:

- Luces direccionales
- Luces de trabajo
- Centella
- Alarma de reversa

Compartimiento del Operador:

- Kit de espejos
- Asiento en suspensión
- Cinturón de seguridad

Panel de Instrumentación:

- Horómetro
- Temperatura de motor
- Alertas baja presión de aceite de motor
- Temperatura de refrigerante
- Indicador de falla

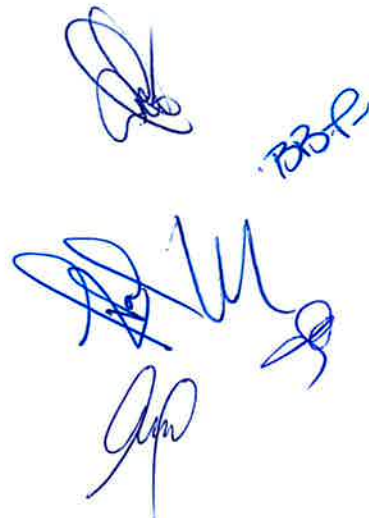
Handwritten signatures and initials in blue ink, including a large signature at the top, the word 'BOOP' to its right, and several other signatures below.

Tiempo de entrega: 4 meses después de colocada la orden de compras y/o adjudicación del contrato.

- **Condiciones de pago:** inicial del 50%, 30% antes de la salida de fábrica y 20% restante con la entrega.

S SERIES®



S40



40/45/50/55/60

MAX LOAD CAPACITY

8000/9000/10000/11000/12000 lbs.

(3628 / 4082 / 4535 / 4989 / 5443 kg)



SMART STRONG SAFE

CLARK S-SERIES products are designed with one goal in mind, providing a solution to customers that is SMART, STRONG, and SAFE. The S40-60 IC Pneumatic truck achieves that goal through a solid, rugged frame, integrated Smart Dash, and operator safety features that are second to none. Designed with the operator in mind, and built to suit a wide variety of applications, the S40-60 will keep your operation moving forward for years to come.



SMART

The S40-60 integrates SMART features including:

- High-resolution 5" interactive dash
- Engine Powertrain protection
- On-board diagnostics thru display screen
- Selectable engine performance modes on the LPG truck
- Optional SMART equipment such as a turn-on vertical mast system and a load weight measurement system

STRONG

The S40-60 built on the CLARK™ built to last™ commitment with STRONG features including:

- Fully-vented heavy gauge frame
- Insulated 14-gauge top and bottom
- 6-Roller-bearing pin external exhaust rollers
- Proven shock absorbers and cooling systems
- Force-cooled wet disc brakes

SAFE

CLARK products are rooted in safety, and the latest S-SERIES continues that tradition with excellent SAFE features including:

- Self-activating parking brake
- Advanced ergonomics for operator safety and productivity
- Increased operator visibility
- Designed with optimal center-of-gravity to enhance truck stability
- Optional safety equipment including speed limit control and a rear view camera

Advanced Ergonomics



- Minimized vibration and noise in operator compartment
- Adjustable full-suspension seat provides comfort over long shifts
- Hood mounted levers with long input force
- Large footboard for larger boots and increased leg room
- 11.8" steering wheel with splined knob standing
- Adjustable tilt steering column
- Optimized step height for ease of entry/exit

Solid and Versatile



- Free-tyred transmission
- Open core square fin aluminum radiator
- Increased visibility due to hooded exhaust
- Standard engine air pre-cleaner
- Optional center of gravity for increased stability
- Fully-welded heavy gauge frame provides lasting durability

Advanced Componentry



- High-visibility 5" LCD interactive display with vital and audible warnings
- Advanced CANbus communication provides robustness, speed and built-in error detection between electronic devices
- Fault codes display on screen for ease of serviceability
- Two selectable performance modes for balance between productivity and fuel economy on the LPG truck
- Dash integrates with optional equipment including backup camera

Kubota LPG or Diesel Engine



- Kubota V6330U LPG Engine
- CARB and EPA Certified
- Peak power of 55.2 hp is achieved at 2200 rpm
- 11w-4 Final Kubota V6330U Diesel Engine
- Diesel Oxidation Catalyst
- No regeneration (burn off) cycles
- Peak power of 74.3 hp is achieved at 2200 rpm
- Power output is optimal in the rpm range where it is needed most



SMART STRONG SAFE

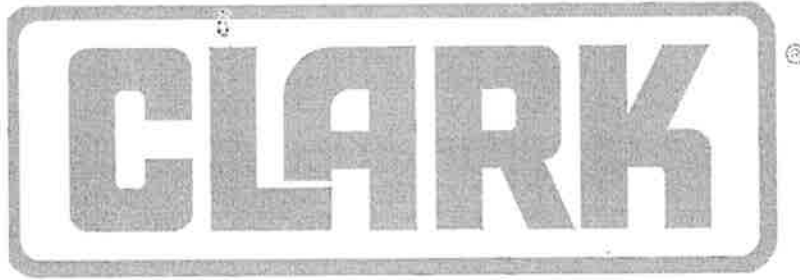

CLARK: The Innovative and Durable Solution

The design, development, and manufacturing capabilities of CLARK, in combination with an unparalleled focus on customer support, a drive to understand fully each customer's needs in order to then supply the right solution, reflect the key essence of what is CLARK.

With over one million CLARK lift trucks sold around the world, each is a testament to the CLARK time-tested process of designing durable trucks with precise features that meet, if not exceed, the material handling needs of our customers. Our full range of dependable products – from pallet jacks to electric narrow aisle order selectors and up to our big 18,000lb capacity lift trucks – assures end-users CLARK has the solutions for their day-to-day needs.



These solutions built from industry innovations, from the nested I-Beam to a self-activating parking brake to new on-board diagnostics, began the same way: with the needs of our customers foremost in mind. By focusing on how we can improve our customers' material handling processes, we can assure our customers a lift truck designed to be the right solution for their needs.

When you bring it all together – an extensive research and development process, state-of-the-art manufacturing capabilities, and a superior dealership network – you have a company dedicated to delivering leading edge products for both today and far into the future. More reasons why CLARK is Built to Last®.

"CLARK, TOTALIFT, Powrworker, PartsPRO Plus, and Built to Last are registered in the U.S Patent and Trademark office. The "Hot Yellow Green" also known as "CLARK Green" is a trademark registered in the U.S Patent and Trademark office."



59-894-2022

CLARK MATERIAL HANDLING COMPANY
North American Headquarters
700 Enterprise Drive • Lexington, KY 40510
866-252-5275 • www.clarkmhc.com

S40-60
59-894-2022 Printed in USA OTP0820500
© 2022 CLARK Material Handling Company

Garantía:**Garantía**

1 año o 2,000 horas en el equipo. 2 años o 4,000 horas en componentes mayores (motor, transmission) y 3 años o 6,000 horas en los frenos de discos humedo. Siempre que la operación y mantenimiento sean de acuerdo a lo especificado por el fabricante.

NOTA: De realizarse el pago en pesos dominicanos, la conversión debe efectuarse en base a la tasa del dólar establecida por EQUIMAX.

➤ **Validez de la cotización: 120 días.**

A la espera de ser favorecidos con su grata orden, se despide,

Ing. Lorenzo Tejada
Gerente de Ventas
(809) 561-2222 Ext. 3622
Cel. 829-754-6208
ltejada@equimax.com.do

➤

M R
BOL
GPO \$

Patines Hidráulicos

• Patín Hidráulico Standard

CJ55	
Capacidad de carga.	5500 lbs.
Longitud de horquilla	48"
Ancho total de la horquilla	20.5"/27"
Altura baja de la horquilla	2.9"
Altura de horquilla elevada	7.8"
Ancho de la horquilla	6.5"
Peso	170 lbs.
Ruedas de dirección	7"
Rodillos de carga	2.9" X 3.6"
Ruedas / Rodillos	Poliuretano



Patines Hidráulicos

• Descripción CJ55

- Durable, versátil y fácil de usar, las características del CJ55 con un diseño ergonómico que reduce la fatiga del operador y tiempo de inactividad.
- Mango con pivote de 200 grados proporciona maniobrabilidad excepcional en áreas compactas y viene con ruedas de poliuretano estándar y rodillos para dar un rodado fácil y ligero.

CJ55 PALLET TRUCK
FRAME ASSEMBLY PARTS BREAKDOWN

CLARK

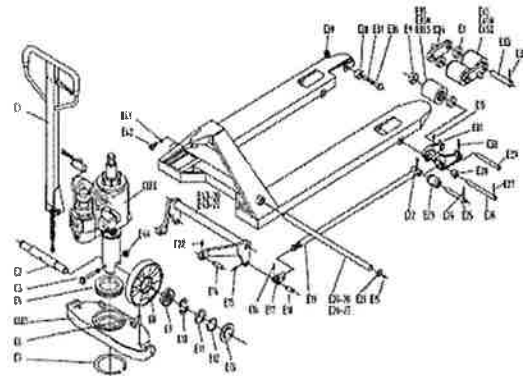

Patines Hidráulicos

• Características estándar CJ55

- **Bastidor**
 - Bastidor resistente para trabajo pesado construido en una sola pieza, formado en acero acanalado ofreciendo mayor resistencia con un peso más ligero.
- **Horquillas**
 - Reforzadas para dar mayor resistencia con extremos cónicos facilita la entrada en las tarimas
- **Pintura**
 - La serie CJ55 cuenta con un acabado en pintura en polvo de calidad
- **Bomba Hidráulica**
 - Diseño de calidad con una válvula de descenso especial, permitiendo una velocidad en descenso controlada con una válvula de sobrecarga
- **Palanca de control**
 - Con base reforzada, la manija de resorte automático regresa a la posición vertical automáticamente
- **Manija de control**
 - Con base reforzada, la palanca de resorte automático regresa a la posición vertical automáticamente. la palanca de control tiene tres posiciones (Elevar/Neutral/Bajar) total control con las yemas de los dedos. Diseño ergonómico y libre de puntos de pellizcos.
- **Bomba Presión**
 - Cuenta con un total de 90° grados de la parte superior a la parte inferior

Patines Hidráulicos

• Características estándar CJ55

- **Rodillos de Carga**
 - Cuenta con rodillos de poliuretano de 2.9" con baleros sellados
- **Dirección**
 - Ofrece un pivote de 200° grados para mayor maniobrabilidad, con ruedas de poliuretano de 7", baleros sellados y baleros de bolas en la dirección.
- **Barras de Empuje**
 - Varillas de empuje ajustables individualmente con capacidad de ajuste a cualquier altura de las horquillas
- **Levantadores**
 - Levantadores son una sola pieza, están fabricados de hierro fundido para mayor resistencia y durabilidad.
- **Rodillos Auxiliares**
 - Cuenta con cuatro rodillos auxiliares para dar una fácil entrada y salida de las tarimas
- **Puntos de Pivote**
 - El CJ55 cuenta con engrasadores y bujes en todos los puntos de pivotes para darle un mejor y fácil mantenimiento
- **Opciones de Ruedas**
 - Ruedas de Nylon
 - Ruedas de acero